

# *AccuPyc<sup>®</sup> II 1345*

---

*GAS DISPLACEMENT PYCNOMETER*



**micromeritics<sup>®</sup>**

***OPERATOR MANUAL***

---

134-42851-01  
Jan 2021  
(Rev A)

## TRADEMARKS

---

*AccuPyc is a registered trademark of Micromeritics Instrument Corporation.*

*Micromeritics is a registered trademark of Micromeritics Instrument Corporation.*

*Microsoft and Windows are registered trademarks of Microsoft Corporation.*

*Scientech is a registered trademark of Scientech, Inc.*

*This application may contain a binary form of the Info-ZIP tool to create .zip files. That source code is provided under the following license:*

*This software is provided "as is," without warranty of any kind, express or implied. In no event shall Info-ZIP or its contributors be held liable for any direct, indirect, incidental, special or consequential damages arising out of the use of or inability to use this software.*

*Permission is granted to anyone to use this software for any purpose, including commercial applications, and to alter it and redistribute it freely, subject to the following restrictions:*

1. Redistributions of source code must retain the above copyright notice, definition, disclaimer, and this list of conditions.
2. Redistributions in binary form must reproduce the above copyright notice, definition, disclaimer, and this list of conditions in documentation and/or other materials provided with the distribution.
3. Altered versions — including, but not limited to, ports to new operating systems, existing ports with new graphical interfaces, and dynamic, shared, or static library versions — must be plainly marked as such and must not be misrepresented as being the original source. Such altered versions also must not be misrepresented as being Info-ZIP releases — including, but not limited to, labeling of the altered versions with the names "Info-ZIP" (or any variation thereof, including, but not limited to, different capitalizations), "Pocket UnZip," "WiZ" or "MacZip" without the explicit permission of Info-ZIP. Such altered versions are further prohibited from misrepresentative use of the Zip-Bugs or Info-ZIP e-mail addresses or of the Info-ZIP URL(s).
4. Info-ZIP retains the right to use the names "Info-ZIP," "Zip," "UnZip," "WiZ," "Pocket UnZip," "Pocket Zip," and "MacZip" for its own source and binary releases.

## Copyright

The software described in this manual is furnished under a license agreement and may be used or copied only in accordance with the terms of the agreement.

## WARRANTY

---

MICROMERITICS INSTRUMENT CORPORATION warrants for one year from the date of shipment each instrument it manufactures to be free from defects in material and workmanship impairing its usefulness under normal use and service conditions except as noted herein.

Our liability under this warranty is limited to repair, servicing and adjustment, free of charge at our plant, of any instrument or defective parts when returned prepaid to us and which our examination discloses to have been defective. The purchaser is responsible for all transportation charges involving the shipment of materials for warranty repairs. Failure of any instrument or product due to operator error, improper installation, unauthorized repair or alteration, failure of utilities, or environmental contamination will not constitute a warranty claim. The materials of construction used in MICROMERITICS instruments and other products were chosen after extensive testing and experience for their reliability and durability. However, these materials cannot be totally guaranteed against wear and/or decomposition by chemical action (corrosion) as a result of normal use.

Repair parts are warranted to be free from defects in material and workmanship for 90 days from the date of shipment.

No instrument or product shall be returned to MICROMERITICS prior to notification of alleged defect and authorization to return the instrument or product. All repairs or replacements are made subject to factory inspection of returned parts.

MICROMERITICS shall be released from all obligations under its warranty in the event repairs or modifications are made by persons other than its own authorized service personnel unless such work is authorized in writing by MICROMERITICS.

The obligations of this warranty will be limited under the following conditions:

1. Certain products sold by MICROMERITICS are the products of reputable manufacturers, sold under their respective brand names or trade names. We, therefore, make no express or implied warranty as to such products. We shall use our best efforts to obtain from the manufacturer, in accordance with his customary practice, the repair or replacement of such of his products that may prove defective in workmanship or materials. Service charges made by such manufacturer are the responsibility of the ultimate purchaser. This states our entire liability in respect to such products, except as an authorized person of MICROMERITICS may otherwise agree to in writing.
2. If an instrument or product is found defective during the warranty period, replacement parts may, at the discretion of MICROMERITICS, be sent to be installed by the purchaser, e.g., printed circuit boards, check valves, seals, etc.
3. Expendable items, e.g., sample tubes, detector source lamps, indicator lamps, fuses, valve plugs (rotor) and stems, seals and O-rings, ferrules, etc., are excluded from this warranty except for manufacturing defects. Such items which perform satisfactorily during the first 45 days after the date of shipment are assumed to be free of manufacturing defects.

Purchaser agrees to hold MICROMERITICS harmless from any patent infringement action brought against MICROMERITICS if, at the request of the purchaser, MICROMERITICS modifies a standard product or manufactures a special product to the purchaser's specifications.

MICROMERITICS shall not be liable for consequential or other type damages resulting from the use of any of its products other than the liability stated above. This warranty is in lieu of all other warranties, express or implied, including but not limited to, the implied warranties of merchantability or fitness for use.

---

## ***CORPORATE PROFILE***

---

Micromeritics Instrument Corporation is the world's leading supplier of high-performance systems to characterize particles, powders and porous materials with a focus on physical properties, chemical activity, and flow properties. Our technology portfolio includes: pycnometry, adsorption, dynamic chemisorption, particle size and shape, intrusion porosimetry, powder rheology, and activity testing of catalysts. The company has R&D and manufacturing sites in the USA, UK, and Spain, and direct sales and service operations throughout the Americas, Europe, and Asia. Micromeritics systems are the instruments-of-choice in more than 10,000 laboratories of the world's most innovative companies, prestigious government, and academic institutions. Our world-class scientists and responsive support teams enable customer success by applying Micromeritics technology to the most demanding applications. For more information, please visit [www.Micromeritics.com](http://www.Micromeritics.com).

---

## ***CONTACT US***

---

### **Micromeritics Instrument Corporation**

4356 Communications Drive  
Norcross, GA / USA / 30093-2901  
Phone: 1-770-662-3636  
Fax: 1-770-662-3696  
[www.Micromeritics.com](http://www.Micromeritics.com)

### **Instrument Service or Repair**

Phone: 1-770-662-3666  
International — contact your local distributor or call 1-770-662-3666  
[Service.Helpdesk@Micromeritics.com](mailto:Service.Helpdesk@Micromeritics.com)

### **Micromeritics Learning Center**

Phone: 1-770-662-3607  
[www.Micro.edu](http://www.Micro.edu)

## ABOUT THIS MANUAL

---

Log in to your [customer portal](#) to access the following:

- Calculations
- Error Messages

Parts and accessories can be found online at [www.Micromeritics.com](http://www.Micromeritics.com).

The following symbols indicate safety precautions and/or supplemental information and may appear in this manual:



**NOTE** — Notes contain important information applicable to the topic.



**CAUTION** — Cautions contain information to help prevent actions that may damage the analyzer or components.



**WARNING** — Warnings contain information to help prevent actions that may cause personal injury.

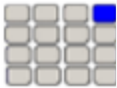

**KEYPAD FUNCTION** — The keypad icon indicates the section is applicable only when using the keypad.



**NOTE** — Notes that apply to 21CFR11 environments only (Confirm applications).

## GENERAL SAFETY

---



Do not modify this instrument without the authorization of a Micromeritics service personnel.

---

Any piece of laboratory equipment can become dangerous to personnel when improperly operated or poorly maintained. All employees operating and maintaining Micromeritics instruments should be familiar with its operation and should be thoroughly trained and instructed on safety.

- Read the manual for any special operational instructions for the instrument.
  - Know how the instrument functions and understand the operating processes.
- 



- Wear the appropriate personal protective equipment when operating this instrument — such as eye protection, lab coat, protective gloves, etc.
  - When lifting or relocating the instrument, use proper lifting and transporting devices for heavy instruments. Ensure that sufficient personnel are available to assist in moving the instrument. The AccuPyc 1345 weighs approximately 7.9 - 26 kg (17 - 51 lb) depending on configuration.
  - Always pay attention to the safety instructions provided on each label affixed to the instrument and do not alter or remove the labels. When inspecting the instrument, ensure that the safety labels have not become worn or damaged.
  - The AccuPyc 1345 sound level is below 80 dBA. Hearing protection is optional.
  - Proper maintenance is critical to personnel safety and smooth instrument operation and performance. Instruments require regular maintenance to help promote safety, provide an optimum end test result and to prevent costly down time. Failure to practice proper maintenance procedures can lead to unsafe conditions and shorten the life of the instrument.
  - Improper handling, disposing of, or transporting potentially hazardous materials can cause serious bodily harm or damage the instrument. Always refer to the MSDS when handling hazardous materials. Safe operation and handling of the instrument, supplies, and accessories is the responsibility of the operator.
- 

## INTENDED USE

The AccuPyc II 1345 Series Pycnometers are fast, fully automatic pycnometers that provide high-speed, high-precision volume measurements and true density calculations on a wide variety of powders, solids, and slurries. After analyses are started with a few keystrokes, data are collected, calculations are performed, and results displayed. A minimal amount of operator attention is required.



The instrument is intended to be operated by trained personnel familiar with the proper operation of the equipment recommended by the manufacturer as well as relevant hazards involved and prevention methods. All use, other than that described in this manual, is seen as unintended use and can cause a safety hazard.



The instrument is intended to be used as per applicable local and national regulations.

## ***TRAINING***

It is the responsibility of the customer to ensure that all personnel operating or maintaining the equipment participate in training and instruction sessions. All personnel operating, inspecting, servicing, or cleaning this instrument must be properly trained in operation and machine safety before operating this instrument.



## ENVIRONMENTALLY FRIENDLY USE PERIOD

### Hazardous Substances Table

Part Name	Hazardous Substances					
	Lead (Pb)	Mercury (Hg)	Cadmium (Cd)	Hexavalent Chromium (Cr (VI))	Polybrominated biphenyls (PBB)	Polybrominated diphenyl ethers (PBDE)
<b>Metal Parts</b>	x	o	o	o	o	o
<b>Power Supplies</b>	x	o	o	o	o	o
<b>Printed Circuit Boards</b>	x	o	o	o	o	o

- o Hazardous substance is below the specified limits as described in SJ/T11363-2006.
- x Hazardous substance is above the specified limits as described in SJ/T11363-2006.

The Environmentally Friendly Use Period (EFUP) for all enclosed products and their parts are per the symbol shown here, unless otherwise marked. Certain parts may have a different EFUP (for example, battery modules) and so are marked to reflect such. The Environmentally Friendly Use Period is valid only when the product is operated under the conditions defined in the product manual.



---

## Table of Contents

Warranty .....	i
Corporate Profile .....	ii
Contact Us .....	iii
About this Manual .....	iv
General Safety .....	v
<b>1 About the AccuPyc II .....</b>	<b>1 - 1</b>
Instrument Components .....	1 - 2
About the TEC Module .....	1 - 4
Asphalt Density Application .....	1 - 5
About the FoamPyc Module .....	1 - 5
Equipment Options and Upgrades .....	1 - 7
Configuration Options .....	1 - 8
Gas Requirements .....	1 - 10
Specifications for AccuPyc II .....	1 - 11
Specifications for AccuPyc II TEC .....	1 - 15
<b>2 Data Entry with Keypad .....</b>	<b>2 - 1</b>
About the Display .....	2 - 2
About the Keypad .....	2 - 3
System Commands .....	2 - 6
Cancel an Analysis .....	2 - 8
Manual Mode .....	2 - 9
Transmit Data .....	2 - 10
Analysis Parameters .....	2 - 10
Review Data .....	2 - 13
View Data Results .....	2 - 15
Print a File .....	2 - 15

<b>3 About the Software</b>	<b>3 - 1</b>
Menu Structure	3 - 1
Common Fields and Buttons	3 - 2
Option Presentation	3 - 5
File Status	3 - 7
Keyboard Shortcuts	3 - 8
Default Methods	3 - 9
Analyzer Status	3 - 10
Show Instrument Log	3 - 10
Show Instrument Schematic	3 - 11
Show Status	3 - 13
Export Files	3 - 14
List Files	3 - 14
Open a Sample File	3 - 15
Software Updates	3 - 16
Reinstall or Modify the Software	3 - 17
Software Uninstall	3 - 18
Unit Selection	3 - 18
Software in 21CFR11 Environments	3 - 19
Option Presentation for 21CFR11 Environments	3 - 21
Uninstall Software in 21CFR11 Environments	3 - 23
<b>4 Sample Files</b>	<b>4 - 1</b>
Create Sample Files	4 - 1
Sample Cup	4 - 5
Material Parameters	4 - 6
<b>5 Parameter Files</b>	<b>5 - 1</b>
Analysis Conditions	5 - 2
Report Options	5 - 5
<b>6 Perform an Analysis</b>	<b>6 - 1</b>
Prepare and Load a Sample	6 - 1

---

Perform an Analysis using the Software .....	6 - 3
Perform an Analysis using the Keypad .....	6 - 5
QuickStart Analysis .....	6 - 7
Sequence Analysis .....	6 - 8
Review Analysis .....	6 - 9
<b>7 About Reports .....</b>	<b>7 - 1</b>
Open and Close Reports .....	7 - 1
Start Reports .....	7 - 1
SPC Report .....	7 - 2
Report Features and Shortcuts .....	7 - 6
Graph Features and Shortcuts .....	7 - 10
Graph and Sample Overlays .....	7 - 15
Generate Multiple Graph Overlays .....	7 - 15
Generate Multiple Sample Overlays .....	7 - 17
Report Examples for Pycnometry Analyzers .....	7 - 19
Combined Report .....	7 - 19
Summary Report .....	7 - 20
Tabular Report .....	7 - 21
Graph Report .....	7 - 22
Overlay Report .....	7 - 23
Equilibration Report .....	7 - 24
Sample Log Report .....	7 - 25
<b>8 Selected Reports .....</b>	<b>8 - 1</b>
Combined Report .....	8 - 1
Density and Volume Table .....	8 - 2
Density Volume vs Cycle Number Trend Plot .....	8 - 3
Density vs Time Trend Plot .....	8 - 5
Equilibration Report .....	8 - 6
Options Report .....	8 - 8
Pressure and Volume Table .....	8 - 8
Sample Log Report .....	8 - 9

Summary Report .....	8 - 9
Total Pore Volume vs Temperature .....	8 - 10
Volume vs Cycle Number Trend Plot .....	8 - 11
<b>9 Diagnostics using the Software .....</b>	<b>9 - 1</b>
<b>10 About Calibration .....</b>	<b>10 - 1</b>
Calibrate Using the Software .....	10 - 1
Calibrate Pressure Scale .....	10 - 1
Calibration Report .....	10 - 2
Calibrate Temperature Offset .....	10 - 3
Calibrate Zero Cell Volume .....	10 - 4
Calibrate Zero Pressure .....	10 - 5
Reset Pressure Calibration .....	10 - 6
Calibrate Volume Scale .....	10 - 7
Verify Operation .....	10 - 11
Load Calibration from File .....	10 - 13
Save Calibration to File .....	10 - 13
Calibrate Using the Keypad .....	10 - 14
Calibrate Function .....	10 - 14
Calibration Data .....	10 - 15
Calibrate Volume .....	10 - 16
Reset Pressure Calibration .....	10 - 17
Review Calibration .....	10 - 18
Calibrate Temperature .....	10 - 20
Zero the Pressure Transducer & Chamber Volume .....	10 - 20
Load Calibration Data from a USB Media .....	10 - 21
Copy Calibration Data to a USB Media .....	10 - 21
<b>11 Hardware .....</b>	<b>11 - 1</b>
Add Analysis Module to Control Module .....	11 - 1
Analytical Balance .....	11 - 3
Brightness Control .....	11 - 4

---

Handling System Components .....	11 - 5
RS232 Pin Assignment .....	11 - 6
<b>12 Maintenance and Troubleshooting .....</b>	<b>12 - 1</b>
Power .....	12 - 4
Chamber Cap O-Ring .....	12 - 5
Check the Cell and Expansion Chambers for Leaks .....	12 - 7
Clean the Dust Filter .....	12 - 9
Clean the Pycnometer .....	12 - 10
Decontamination of the Pycnometer .....	12 - 10
Guidelines for Connecting Gases .....	12 - 11
Replace a Gas Cylinder .....	12 - 12
Regulator Pressure .....	12 - 15
Recover From a Power Failure .....	12 - 17
Reset the Pycnometer .....	12 - 17
Power Instrument On and Off .....	12 - 18
Service Test Mode .....	12 - 19
Parts Replacement .....	12 - 19
<b>13 TEC Module .....</b>	<b>13 - 1</b>
Set the TEC Temperature .....	13 - 1
Operate the TEC Module .....	13 - 2
Volume Change with Temperature for the 10 cm <sup>3</sup> AccuPyc .....	13 - 2
Volume Change with Temperature for the 100 cm <sup>3</sup> AccuPyc .....	13 - 3
Asphalt Density Measurement .....	13 - 4
<b>14 Temperature-Controlled AccuPyc .....</b>	<b>14 - 1</b>
Attach a Circulating Bath .....	14 - 1
Add Analysis Modules to a Temperature Controlled Module .....	14 - 2
<b>15 MultiVolume Insert Option .....</b>	<b>15 - 1</b>
<b>16 Multigas Option .....</b>	<b>16 - 1</b>

---

<b>A Advanced Reports - Python Module</b>	<b>A - 1</b>
Advanced Report Options	A - 2
Graphic Reports	A - 3
Add a Curve	A - 3
Add a Curve Using the Second Y-Axis	A - 4
Create a New Graphical Report	A - 4
Scripts	A - 6
Run a Script	A - 6
Remove a Script	A - 6
Edit a Script	A - 7
Python Reports	A - 8
Graphic Report	A - 8
Summary Report	A - 9
Tabular Report	A - 10
Enable the Use of Overlay Data	A - 11
MicModule Python Calls	A - 13
Tables	A - 13
Summary Reports	A - 14
Graphic Reports	A - 15
Get Sample Information Item	A - 17
<b>B Exported Data Example</b>	<b>B - 1</b>
<b>C Sample Volume Equation Derivation</b>	<b>C - 1</b>
<b>D Transmitted Data</b>	<b>D - 1</b>
<b>AccuPyc 1345 CE Declaration of Conformity</b>	<b>DoC - 1</b>
<b>Index</b>	<b>Index - 1</b>

**Blank Page**

---



## 1 ABOUT THE ACCUPYC II

---



Gas pycnometry is recognized as one of the most reliable techniques for obtaining true, absolute, skeletal, and apparent volume and density. This technique is non-destructive as it uses the gas displacement method to measure volume. Inert gases, such as helium or nitrogen, are used as the displacement medium. Density calculations using the gas displacement method are much more accurate and reproducible than the traditional Archimedes water displacement method.

The AccuPyc II Pycnometers are fast, fully automatic pycnometers that provide high-speed, high-precision volume measurements and true density calculations on a wide variety of powders, solids, and slurries. The instrument completes most sample analyses in less than three minutes without sacrificing accuracy. After analyses are started with a few keystrokes, data are collected, calculations are performed, and results displayed. A minimal amount of operator attention is required. The pycnometer can be controlled by either:

- **Windows 10 interface.** The operational status of the pycnometer can be continually monitored in the application. If the Windows interface is used, the keypad is disabled.
- **The keypad if not running the Windows interface.** A separate keyboard and printer can be attached to the pycnometer using USB ports.

## INSTRUMENT COMPONENTS

### FRONT COMPONENTS

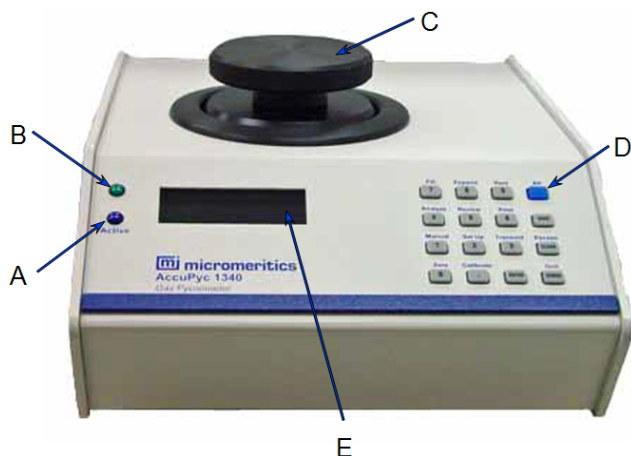

The sample chamber, located on the top panel, is where the sample cup is placed for analysis.

The sample chamber should remain capped except when inserting or removing a sample. When left uncapped, water vapor adsorbs on the inner surface of the chamber or the chamber temperature becomes unstable; either condition can affect analysis results. If water vapor accumulates in the chamber, the pycnometer must be purged.

The standalone control module, often used for the Glove Box pycnometer, does not contain a sample chamber. See [Glove Box on page 1 - 9](#).

### Front Components

Component	Description
<b>A</b> Active indicator	A blue LED which illuminates when an operation is in progress. It is included on all analysis modules. It is not included on standalone control modules.
<b>B</b> Power indicator	A green LED which illuminates when the analyzer is powered on.
<b>C</b> Sample chamber	For inserting sample material.
<b>D</b> Keypad	For operating the pycnometer without the Windows application.
<b>E</b> Display window	Displays <i>Remote Operation</i> when the Windows application is being used. The AccuPyc can be operated in the keypad mode when the Windows application is closed.

## BACK COMPONENTS

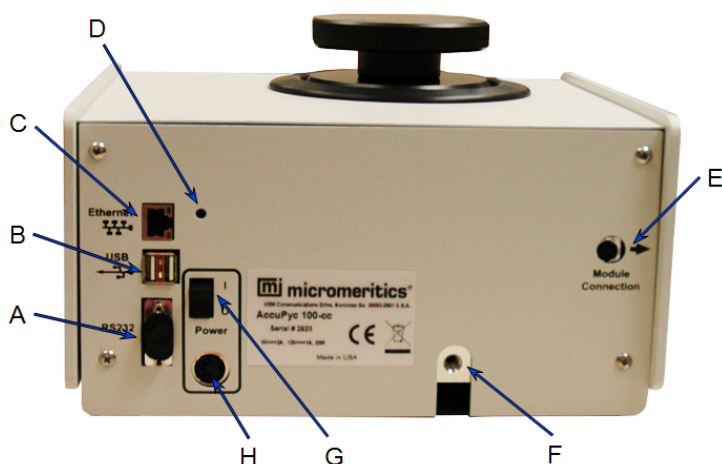

### Back Components

Component	Description
	Dust filter ( <i>not shown</i> ) (For 2000 cm <sup>3</sup> units and high pressure units only.) Traps sample dust to protect internal valves.
<b>A</b>	RS232 port Used to transmit data only when using the keypad function. Also used to connect to the analytical balance.
<b>B</b>	USB connectors Use for connecting a keyboard, printer, or balance to the instrument.
<b>C</b>	Ethernet port Provides for setting up for e-mailing reports, sending data to a web browser, or interfacing with the AccuPyc Windows application.
<b>D</b>	Brightness control Used to adjust the brightness of the display. See <a href="#">Brightness Control on page 11 - 4</a> .
<b>E</b>	Analysis module connector Used to connect up to five analysis modules to the initial control / analysis module. Each module contains analysis module input and output connectors.
<b>F</b>	Gas inlet port Use to connect the analysis gas; helium is recommended. If multiple analysis modules are attached, each module contains a gas inlet port. Multiple gases can be attached using the Multigas option. See <a href="#">Multi-gas Option on page 16 - 1</a> .
<b>G</b>	ON/OFF switch For powering the analyzer on and off.
<b>H</b>	Power connector For connecting the power source to the instrument using a mini-DIN cable.

## ABOUT THE TEC MODULE

- [TEC Module on page 13 - 1](#)



Density measurements at specific temperatures are required for certain applications. The AccuPyc II Thermo Electric Cooling (TEC) Module maintains an accurate temperature control during analysis using the principle of Peltier cooling.

TEC Modules, also known as Peltier coolers, are solid-state heat pumps that utilize the Peltier effect to move heat. By passing a current through the TEC Module, heat is transferred from one side of the module to the other, typically producing a heat differential of approximately 40° C.

The transferred heat is then removed from the system through the combination of a heat sink and fan, cooling the system to maintain a set temperature for accurate analysis.

TEC systems feature:

- fast dynamic response
- long-life
- no moving parts
- no use of refrigerants or circulated liquids / antifreeze

## ***ASPHALT DENSITY APPLICATION***

The AccuPyc II TEC Module can measure asphalt density using disposable cups to limit cross-contamination of samples. To show cup properties and asphalt options, go to **Options > Option Presentation** and enable *Show Cup Properties* and *Show Asphalt Options*.

This solution can be closely correlated (< 0.15% difference) to results obtained with ASTM Test Method D70-09. The AccuPyc asphalt density measurement is completed much faster than the ASTM method while virtually eliminating operator error. The Peltier thermoelectric cooling control (15 to 36 °C) provides stability for handling of samples.

## ***ABOUT THE FOAMPYC MODULE***

A FoamPyc option for measuring open and closed cell foam materials is available for both standard and temperature-controlled pycnometers. This unit can be ordered initially with the FoamPyc application installed, or can be upgraded from the standard AccuPyc with a software enhancement via USB media. Configuration options are:

- 100 cm<sup>3</sup> nominal cell volume (recommended)
- 10 cm<sup>3</sup> nominal cell volume

The FoamPyc option performs analyses on materials such as polystyrene, urethane, and rubber foams using five different methods:

- **Correction using cell dimensions.** Measures the closed cell fraction and corrects for the cells damaged while cutting the sample to the necessary size and shape. This is accomplished by using either the average cell diameter or the cell chord length (as defined in ASTM method D-6226-15) and the measurements of the sample to determine the volume of the cut cells. This volume is deducted from the total volume of the open cells measured by the pycnometer.
- **Correction by recutting sample.** Corrects for the cut cells by using two separate measurements. For the 2nd measurement, the sample is recut to double the amount of cut surface. The observed difference in cut open cell volume is applied as a correction to the initial measured volume. This method offers the distinct advantage that no assumptions are needed about the relative amounts of open and closed cells.
- **No correction.** Does not correct for cut cells. It is used for materials with predominantly open cells where good accuracy can be achieved without correction. The accuracy level deteriorates as the percentage of closed cells increases.
- **Compressibility test.** The fill pressure is increased incrementally over the sample with each repeat of the P1, P2 cycle (where P1 is the initial pressure to which the sample is charged, and P2 the final pressure after expansion). The apparent variation of the measured sample volume with the average pressure is determined. This test is an approximate indication. It is not intended to be an exact measure of the volume compressibility.
- **Cell fracture test.** A perfectly rigid foam is assumed. First, a P1, P2 cycle is performed at the lower of two specified P1 pressures, and the results stored. A second cycle is performed at a

higher specified value of P1, then a third cycle identical to the first cycle is performed. The difference between the volume of the sample on the first measurement and on the third measurement is reported as the volume of fractured cells. It is assumed that cells fracture by exposure to the highest pressure (2nd cycle) so that when the third measurement is made, the measured sample volume has decreased from the first cycle by the amount of the closed cell volume which was fractured.

The 100 cm<sup>3</sup> AccuPyc II has been designed and tested to follow the procedure in ASTM Method D 6226 for FoamPyc analyses. The 10 cm<sup>3</sup> and 350 cm<sup>3</sup> units can be used for some types of foam materials; however, analyses on these AccuPycs will not conform to the ASTM method. The 1 cm<sup>3</sup> AccuPyc II cannot be used to perform FoamPyc analyses.

The FoamPyc software also provides the capability to perform analyses in the *Standard* mode of operation. This is especially convenient for users who have upgraded to the FoamPyc method from the standard method. For example, a 100 cm<sup>3</sup> AccuPyc on which FoamPyc analyses are performed and a 1 cm<sup>3</sup> analysis module attached on which standard analyses are performed.

---

## ***EQUIPMENT OPTIONS AND UPGRADES***

---



Parts and accessories can be found online at [www.Micromeritics.com](http://www.Micromeritics.com).

---

### ***HIGH PRESSURE PYCNOMETER***

Gas pycnometry is recognized as one of the most reliable techniques for obtaining skeletal volume and density. The fully automatic AccuPyc High Pressure pycnometer provides high speed, high precision volume measurements and density determinations on intact or crushed shale core samples.

The high pressure pycnometer:

- Operates at a pressure of up to 500 psi to provide a better diffusion of the gas into the rock.
- Has a stainless steel sample chamber with a volume of 100 cm<sup>3</sup>.
- Has a sample chamber that can accommodate a 48 mm (1.85 in.) diameter core of up to 60 mm (2.40 in.) in length.

### ***LARGE VOLUME PYCNOMETER***

The AccuPyc Large Volume pycnometer sample chamber addresses the specific needs of operations that require pore volume knowledge of intact drilling cores. This instrument eliminates the need to break core samples into smaller pieces prior to analysis.

The large volume pycnometer:

- Has a large sample chamber with a volume of approximately 2000 cm<sup>3</sup>.
- Has a sample chamber that can accommodate a 95 mm (3.74 in.) diameter core of up to 278 mm (10.9 in.) in length.

## **MULTIVOLUME INSERTS**

The MultiVolume option is used to analyze smaller sized samples. Options are:

- 1 cm<sup>3</sup> nominal cell volume; contains a 0.1 cm<sup>3</sup> cup
- 10 cm<sup>3</sup> nominal cell volume; contains 1 cm<sup>3</sup> and a 3.5 cm<sup>3</sup> cups
- 100 cm<sup>3</sup> nominal cell volume; contains 10 cm<sup>3</sup> and 35 cm<sup>3</sup> cups
- 2000 cm<sup>3</sup> nominal cell volume, contains 650 cm<sup>3</sup> and 1300 cm<sup>3</sup> cups

Each kit includes inserts, reference standards, and sample cups.

## **MULTIGAS OPTION**

The Multigas Option allows connection of up to four gases to one analyzer. See [Multigas Option on page 16 - 1](#).

## **CONFIGURATION OPTIONS**

For best fit with a sample, the AccuPyc II is available in multiple configurations.



All sample chamber volumes are nominal unless otherwise specified.

- 1 cm<sup>3</sup> sample chamber
- 10 cm<sup>3</sup> sample chamber
- 100 cm<sup>3</sup> sample chamber
- 350 cm<sup>3</sup> sample chamber
- 2000 cm<sup>3</sup> sample chamber
- 100 cm<sup>3</sup> high pressure sample chamber

Best fit means the sample nearly fills the sample chamber and, therefore, optimizes the precision of the results.



## ***GLOVE BOX***

Provides for analysis of samples in which a controlled environment is required.

Options	Description
<b>Configuration</b>	<ul style="list-style-type: none"> <li>■ 1 cm<sup>3</sup> sample chamber</li> <li>■ 10 cm<sup>3</sup> sample chamber</li> <li>■ 100 cm<sup>3</sup> sample chamber</li> <li>■ 350 cm<sup>3</sup> sample chamber</li> <li>■ 2000 cm<sup>3</sup> sample chamber</li> <li>■ 100 cm<sup>3</sup> high pressure sample chamber</li> </ul>

This unit consists of two separate modules. The controller is placed outside the glove box, while the analysis module is placed inside the glove box. Up to six analysis modules may be placed in the glove box, all controlled by one external control module.

## ***TEMPERATURE CONTROLLED MODULE***

Provides for the attachment of an external circulating bath.

Options	Description
<b>Configuration</b>	<ul style="list-style-type: none"> <li>■ 10 cm<sup>3</sup> sample chamber</li> <li>■ 100 cm<sup>3</sup> sample chamber</li> </ul>

The temperature controlled unit is specifically designed for temperature sensitive materials. This unit is ideally suited for laboratories in which ambient temperature varies during normal work hours, or in which subambient cooling is required.

## ***TEC MODULE***

- [About the TEC Module on page 1 - 4](#)
- [Specifications for AccuPyc II TEC on page 1 - 15](#)
- [TEC Module on page 13 - 1](#)

## ***GAS REQUIREMENTS***

- [Guidelines for Connecting Gases on page 12 - 11](#)



Improper handling, disposing of, or transporting potentially hazardous materials can cause serious bodily harm or damage the instrument. Always refer to the MSDS when handling hazardous materials. Safe operation and handling of the instrument, supplies, and accessories is the responsibility of the operator.



Toxic, corrosive, flammable, poisonous, or injurious gases should not be used with the AccuPyc.

The pycnometer uses helium or nitrogen (99.995% pure or better) to provide rapid, accurate analyses. The cylinder containing helium must be fitted with a gas regulator set for 19-23 psig (131-159 kPag). The pressure input to the pycnometer should never be greater than 25 psig (172 kPag). Excessive pressures waste gas due to a protection device contained in the pycnometer that vents the pycnometer to atmospheric pressure if pressure exceeds 35 psig (241 kPag). This protection device is not installed on 2000 cm<sup>3</sup> or high pressure units.



- The High Pressure sample chamber configuration inlet pressure should never be greater than 520 psig (3580 kPag); there is no pressure relief valve.
- Tank pressure should be at least 200 psi above regulator pressure.

Other inert, dry gases can also be used and may be more applicable for some applications.

## SPECIFICATIONS FOR ACCUPYC II

### Environment

Temperature	Stable between 15 to 35 °C (59 to 96 °F) . Temperature-controlled AccuPyc: temperature stability is dependent upon specifications of the installed circulator. Recommended range: 15 to 50 °C (59 to 122 °F).
Humidity	20 to 80% relative (non-condensing)
Indoor/Outdoor Use	Indoor only Altitude: < 2000 m Pollution degree of the intended environment: 2
Operating Pressure	152 kPa (22 psi) max

### Physical

Analysis Module (1, 10, 100 cm <sup>3</sup> )	Height:	20 cm (7.9 in.)
	Width:	22.2 cm (8.7 in.)
	Depth:	36.2 cm (14.3 in.)
	Weight:	7.9 kg (17.4 lbs)
	Weight:	8.2 kg (18.1 lbs), high pressure unit
Analysis Module (350 cm <sup>3</sup> )	Height:	25.9 cm (10.2 in.)
	Width:	22.2 cm (8.7 in.)
	Depth:	36.2 cm (14.3 in.)
	Weight:	10.5 kg (23.2 lbs)
Analysis Module (2000 cm <sup>3</sup> )	Height:	43 cm (17 in.)
	Width:	27 cm (10.6 in.)
	Depth:	36.2 cm (14.3 in.)
	Weight:	26 kg (57 lbs)

### Physical (continued)

Control Module	Height: 14.6 cm (5.8 in.) Width: 27.3 cm (10.7 in.) Depth: 36.2 cm (14.3 in.) Weight: 3.6 kg (8 lbs)
Control Analysis Module	Height: 20 cm (7.9 in.) Width: 27.3 cm (10.7 in.) Depth: 36.2 cm (14.3 in.) Weight: 9.3 kg (20.5 lbs)
500 PSI Module (100 cm <sup>3</sup> )	Height: 20.5 cm (8.1 in.) Width: 22 cm (8.7 in.) Depth: 38 cm (15 in.) Weight: 14.5 kg (32 lbs)

### Electrical

Voltage	90-264V~
Power	30 VA
Frequency	50/60 Hz
External Power Adapter	Manufacturer TRUMPower Part Number TSA42-D21 (R1) Pin 1, 2 Common return Pin 3 +5V Pin 4 N/C Pin 5 12V Shell N/C

## Gases

Research grade helium is recommended. If unavailable, use helium with a dew point of  $-67\text{ }^{\circ}\text{C}$  ( $-88\text{ }^{\circ}\text{F}$ ) or lower. Carbon dioxide, argon, dry air, or nitrogen can also be used for different applications (a multigas option is available for connection of multiple gases).

## Sample Cups

1 cm <sup>3</sup> chamber	1.14 cm ID × 1.1 cm D (0.45 in. ID × 0.44 in. D)
10 cm <sup>3</sup> chamber	1.85 cm ID × 3.95 cm D (0.72 in. ID × 1.55 in. D)
100 cm <sup>3</sup> chamber	4.62 cm ID × 6.18 cm D (1.82 in. ID × 2.43 in. D)
350 cm <sup>3</sup> chamber	5.84 cm ID × 13.94 cm D (2.30 in. ID × 5.49 in. D)
2000 cm <sup>3</sup> chamber	9.52 cm ID × 26.00 cm D (3.80 in. ID × 10.20 in. D)

## Analysis

Precision	<p>Reproducibility is typically to within <math>\pm 0.01\%</math> of the nominal full-scale sample chamber volume.</p> <p>Reproducibility is guaranteed to within <math>\pm 0.02\%</math> of the nominal full-scale volume on clean, dry, thermally equilibrated samples using helium in the <math>15\text{ to }35\text{ }^{\circ}\text{C}</math> range.</p>
Accuracy	Accurate to within $0.03\%$ of reading, plus $0.03\%$ of sample capacity
Gas Consumption	<p>Approximately <math>0.1\text{ cm}^3</math> STP times the nominal cell volume for each cycle</p> <p>Approximately <math>2\text{ cm}^3</math> STP times the nominal cell volume per analysis</p>

## Computer Requirements

A computer is not required if the keypad/display is used. When used in this configuration, data can be sent to a USB equipped printer.

Operating System	Windows 7 Professional or higher operating system is recommended for the best user experience. For 21 CFR Part 11 environments, Windows 10 Professional or Windows 10 Enterprise or higher is required.
Desktop Installation Required	The application should not be installed on a network drive with shared access. Multiple users cannot operate the application at the same time.
10 Base T or 100 Base T Ethernet Port	If the computer is to be connected to a network, two Ethernet ports are required. If more than one Ethernet based unit is connected to the same computer (or if a Smart VacPrep is purchased), an Ethernet switch will also be required.
Read/Write Permissions	All users of the application will need Read/Write permission to all directories and subdirectories where the application is installed. For 21 CFR Part 11 environments, permission may be limited to the installation directory.
Drives	USB port

*Due to continuous improvements, specifications are subject to change without notice.*

## SPECIFICATIONS FOR ACCUPYC II TEC

### Temperature Control

Range	15 to 36 °C, ( $\pm 0.1$ °C)
Control	Adjustable in 0.1 °C increments
Environment	Stable between 15 to 35 °C (59 to 95 °F) 20% to 80% relative humidity
Indoor/Outdoor Use	Indoor only Altitude: < 2000 m Pollution degree of the intended environment: 2

### Physical

Height	28 cm (11 in.)
Width	28.7 cm (11.3 in.)
Depth	36.1 cm (14.2 in.)
Weight	13.8 kg (30.5 lbs)

### Electrical

Voltage	90-264V~
Power	100 VA (TEC) 30 VA (Electronics)
Frequency	50/60 Hz

### Sample Cups

10 cm <sup>3</sup> chamber	1.85 cm ID × 3.95 cm D (0.72 in. ID × 1.55 in. D)
100 cm <sup>3</sup> chamber	4.62 cm ID × 6.18 cm D (1.82 in. ID × 2.43 in. D)

*Due to continuous improvements, specifications are subject to change without notice.*

**Blank Page**

---



## 2 DATA ENTRY WITH KEYPAD

---

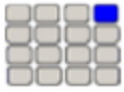

Use these instructions for keypad installations only. If a computer is attached to the module, skip this section. All setup functions will be done in the analysis software.



For instructions on configuring the keypad, see the AccuPyc II 1345 Installation Instructions and Checklist [*part number* 134-42875-02].

Data can be entered into the system using either a:

- **Keypad (or a keyboard).** Used if a computer with the analyzer software installed is not connected to the analyzer. In this case, any section of this manual referring to software can be omitted. All instructions specific to the keypad are designated with the keypad icon.
- **Computer.** Used if the computer with analysis software is installed and connected to the analysis module. In this case, this section of this manual can be skipped.

## ABOUT THE DISPLAY

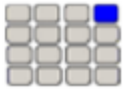

Use these instructions for keypad installations only. If a computer is attached to the module, skip this section. All setup functions will be done in the analysis software.

The display provides information about the analyzer and the current operation. During operations, different types of information are shown in lines two, three, and four. Line one always displays the unit and serial number. If the **Alt** key is pressed, the 3 in 10 cm<sup>3</sup> will change to a + (plus sign). This is an example of the display when the analyzer is in an idle state, or the *Reload* prompt.

Unit[n]	SN 1234	10 cm <sup>3</sup>
	X - X - X	
Reload		
P = (current pressure)		

Line	Description
<b>First</b>	Displays the unit number, serial number, and nominal cell volume of the selected unit. Up to five analysis modules may be attached; though the initial module, containing the keypad and display, will control all units.
<b>Second</b>	At the <i>Reload</i> prompt, manual control, or an automatic operation, this line contains three characters, separated with dashes. The first character represents the <i>Fill</i> valve, the second represents the <i>Expand</i> valve, and the third represents the <i>Vent</i> valve.  Valve states: X = Closed, O = Open  During user interface, this line shows the command currently in use.
<b>Third</b>	Displays status of the current operation, or <i>Reload</i> when in an idle state. When the <i>Reload</i> prompt is displayed, this line may also contain an asterisk (*), indicating there is a message in the queue. During certain functions (such as <i>Setup</i> ), this line contains a prompt for additional information.
<b>Fourth</b>	At the <i>Reload</i> prompt, shows the current pressure and temperature alternately, where: <ul style="list-style-type: none"> <li>■ P = Pressure</li> <li>■ T = Temperature</li> </ul> This line is also used to choose options, enter information, or provide information about the current operation.

## ABOUT THE KEYPAD



A keyboard can be connected to the USB port on the rear panel of the AccuPyc II. Commands can be entered from either the keypad or the keyboard.

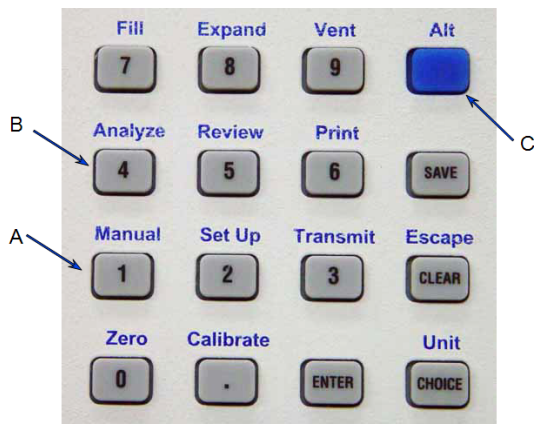

- A. Primary function
- B. Alternate function
- C. ALT key

Most keys on the keypad perform one primary and one alternate function. The primary function of any key is indicated by the number or command on the face of the key. The alternate function is indicated by the command above the key. The top right corner of the display screen will show a + (plus sign) when the **Alt** key is pressed and the alternate function mode is entered. See [About the Display on the previous page](#).

To select the:

- **Primary function.** Press only the key. Primary functions are labeled on the key face. For example; press **4** to enter the number 4.
- **Alternate function.** Press **Alt**, then press the key. Alternate functions have blue labels above the key. For example; press **Alt + 4** to start an analysis. If the **Alt** key is pressed accidentally, pressing it a second time will cancel its function.

The alternate functions for keys **7** (FILL), **8** (EXPAND), and **9** (VENT) are executed differently. Press **Alt + 1** first to enter Manual mode then press the alternate key. For example: press **Alt + 1 + 7** to manually control the Fill valve. Press **Alt + CLEAR** to exit Manual mode.

Functions can be entered from the keyboard.

### Keypad and Keyboard Functions

Keypad Function	Key Sequences		Description
	Keypad	Keyboard	
<b>Decimal (.)</b>	.	.	Enter a decimal point, a dash for sample or instrument ID, a slash for date, or a colon for time.
<b>Number keys (0 through 9)</b>	0 - 9	0 - 9	Enters the numbers 0 through 9.
<b>Calibrate</b>	Alt + . (decimal)	Ctrl + O	Calibrates the pycnometer.
<b>Zero</b>	Alt + 0	Ctrl + Z	Zeroes the pressure transducer.
<b>Manual</b>	Alt + 1	Ctrl + Y	<p>Provides manual control to open and close valves.</p> <ul style="list-style-type: none"> <li>■ Fill (Key 7)</li> <li>■ Expand (Key 8)</li> <li>■ Vent (Key 9)</li> </ul> <div style="border: 1px solid black; padding: 5px; margin: 10px 0;"> <pre>Unit[n]      SN 1234      10 cm3               X - X - X  Reload P = (current pressure)</pre> </div> <p>The state of the valve is shown on the second line of the display, where X=Closed and O=Open.</p> <p><b>Alt + CLEAR</b> exits manual mode.</p>
<b>Set Up</b>	Alt + 2	Ctrl + U	<p>Display or edit:</p> <ul style="list-style-type: none"> <li>■ Analysis parameters</li> <li>■ Report options</li> <li>■ Calibration data</li> <li>■ Data transmission parameters</li> <li>■ Unit types</li> <li>■ Operating language</li> <li>■ Date and time</li> </ul>

## Keypad and Keyboard Functions (continued)

Keypad Function	Key Sequences		Description
	Keypad	Keyboard	
<b>Transmit</b>	Alt + 3	Ctrl + T	Transmits analysis or calibration data. Transmits a partial report if an automatic operation is in progress.
<b>Analyze</b>	Alt + 4	Ctrl + A	Performs an analysis.
<b>Review</b>	Alt + 5	Ctrl + R	Review completed analysis or calibration data.
<b>Print</b>	Alt + 6	Ctrl + P	Prints an analysis or calibration report. If an automatic operation is in progress, prints a partial report.
<b>Unit</b>	Alt + CHOICE + (unit number)	Ctrl I then 1-6	Selects unit (when multiple analysis modules are attached).
<b>Escape</b>	Alt + CLEAR	Esc	Discards all data entered in the current mode and returns to display mode. Cancels an automatic operation in progress. Exits manual mode.
<b>CHOICE</b>	CHOICE	Ctrl + N	Display the next message when in display mode. Display the next multiple choice item when in command mode.
<b>CLEAR</b>	CLEAR	Ctrl + X	Clear a message when in display mode. Clear an entry when in command mode.
<b>ENTER</b>	ENTER	Enter or Ctrl + M	Complete an entry or begin an action.
<b>SAVE</b>	SAVE	Ctrl + W	Save the information and return to display mode.

## SYSTEM COMMANDS

The display of the pycnometer remains at the *Reload* prompt until a command is initiated by pressing a key on the keypad. Commands start an analysis or other automatic operations and allow modification of operating parameters.

Command	Description
Analyze	Performs an analysis
Calibrate	Calibrates pycnometer volume, temperature, or pressure
Manual	Opens and closes valves manually
Print	Prints reports
Review	Reviews the results of the last operation (analysis or calibration)
Set Up	Set up system options and operating parameters
Transmit	Transmits data through a serial communications line
Zero	Zeroes the volume or pressure transducer



While an automatic operation is in progress, no commands can be initiated, other than *Print* or *Transmit*.

A prompt to enter information or choose an option displays on the third and fourth lines of the pycnometer display when a command is entered. The third line contains a description of the requested information and the fourth line displays a default value (when applicable). To use the default value, press **ENTER**. For example, press **Alt + 2** to display:

```
Unit[n]      SN1234      10 cm3
              X - X - X
Setup Type?
Analysis Parameters
```

To select *Analysis Parameters*, which is the default option, press **ENTER**.

If not using the default option, use the keypad to enter or choose other responses. There are two types of prompts:

- Data entry prompts.** Followed by a colon (:). Use the keypad to enter the value, then press **ENTER**. Entering a value that is "out of range" will result in a beep and a message showing the range; enter a value in the range displayed.

- **Multiple choice prompts.** Contain a fixed set of responses followed by a question mark (?). To select a multiple choice response, press **CHOICE** until the response is displayed, then press **ENTER**.

At any time while entering information:

- Press **SAVE** to save the information and return to the *Reload* prompt.
- Press **Alt + CLEAR** to discard the information and return to the *Reload* prompt.

## **CANCEL AN ANALYSIS**

To cancel an analysis, press **Alt + CLEAR**.

```
Unit[n]      SN1234      10 cm3
Analyze
[Enter] to cancel
automatic operation
```

Press **ENTER** within five seconds to cancel the operation. A notification that the automatic operation has been canceled will be displayed.

When canceling an operation, messages are displayed indicating that termination is in progress. The termination process, which vents the system, takes about 30 seconds and returns to the *Reload* prompt.

To view the data that have been collected, press **CHOICE**.

The following prompt is displayed if no cycles have been completed.

```
Unit[n]      SN1234      10 cm3
              X - X - X
DTA_ERR:
No data to compute
```



## MANUAL MODE

Press **Alt + 1** to enter manual mode, allowing manual control of the Bypass, Fill, Expansion, and Vent valves.

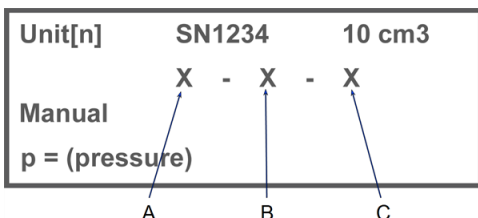

- A. Fill valve
- B. Expansion valve
- C. Vent valve



The Bypass valve is only available on the 2000 cm<sup>3</sup> units and the High Pressure Core Pycnometer units.

Display Text	Description
Manual	<p>When <b>Manual</b> is shown, manually open and close the Fill, Expansion, and Vent valves by pressing:</p> <ul style="list-style-type: none"> <li>■ <b>5</b> - Opens and closes the <b>Bypass</b> valve</li> <li>■ <b>7</b> - Opens and closes the <b>Fill</b> valve</li> <li>■ <b>8</b> - Opens and closes the <b>Expansion</b> valve</li> <li>■ <b>9</b> - Opens and closes the <b>Vent</b> valve</li> </ul> <p>The three characters in the second line of the display show the state of the valves (Fill, Expansion, Vent). <b>X</b> = Closed. <b>O</b> = Open.</p> <p>Press <b>SAVE</b> to exit Manual mode and return to display mode.</p>



Prolonged opening of all three valves at one time may cause excessive loss of helium.

## TRANSMIT DATA

- [Transmitted Data on page D - 1](#)

The AccuPyc RS232 interface transmits report data to a computer using the standard ASCII file format. Reports may be transmitted in a single column format or a spreadsheet format.

- Press **Alt + 3** to transmit report data.
- Press **Alt + CLEAR** to cancel report data transmission.

## ANALYSIS PARAMETERS

This option enables specific analysis and calibration parameters. Although the *Setup Type* is shown as *Analysis Parameters*, these same prompts are used to specify calibration parameters. The pycnometer is shipped with default values; however, these settings may be modified to meet laboratory requirements.

After each selection, press **Enter** to display the next prompt. If data results are to be e-mailed automatically after analysis, specify e-mail parameters using the instructions in the AccuPyc II 1345 Installation Instructions and Checklist [*part number* 134-42875-02].

Enter appropriate analysis and report parameters for the current analysis. The chosen or specified parameters in *Set Up* determine what prompts and information are displayed for the analysis.

Display Text	Description
Setup Type? Analysis Parameters	Press <b>ENTER</b> to accept <i>Analysis Parameters</i> .
Number of Purges:	Key in the number of purges to be performed. Purging cleans the sample cell and expansion chambers before an analysis begins. The greater the number of purges, the cleaner the sample will be when analyzed.  The range is 0 to 999. For calibration, 10 is sufficient.
Purges fill pressure	Key in the fill pressure. For most applications, the default of 19.500 psig is adequate. Typically, the greater the fill pressure, the easier it is to measure the volume precisely. However, a lower pressure may be required for some samples.  The range in psig is 0 to 19.850. The range in kPag is 0 to 136.86.  High Pressure sample chamber:

Display Text	Description
	<p>The range in psig is 0 to 500. The range in kPag is 0 to 3450.</p>
<b>Number of Cycles</b>	<p>Key in the number of cycles to be performed. A cycle is a series of functions which produce a single volume measurement.</p> <p>The range is 1 to 999. For calibration, 10 is sufficient.</p>
<b>Cycle fill pressure</b>	<p>Key in the fill pressure. For most applications, the default of 19.500 psig is adequate.</p> <p>The range in psig is 0 to 19.850. The range in kPag is 0 to 136.86.</p> <p>High Pressure sample chamber:</p> <p>The range in psig is 0 to 500. The range in kPag is 0 to 3450.</p>
<b>P1, P2 end by?</b> [selection]	<p>Choose the manner in which to end the pressure measurement. Press <b>CHOICE</b> to make a selection.</p> <p>The available options are <i>Equilibrate</i> and <i>Fixed interval</i>.</p>
<b>Equilibration Rate: (Does not display for Fixed Intervals)</b>	<p>Select <i>Equilibrate</i> at the <i>P1, P2 end by?</i> prompt. Pressure measurement will end when the entered rate is obtained. Key in the equilibration rate.</p> <p>A high rate will produce faster results, but results may not be as precise as desired. The lowest rates may cause errors when some materials (such as those with appreciable vapor pressures or organics) are analyzed.</p> <p>The default setting is 0.0050 psig/min. The range in psig/min is 0.0001 to 9.0000. The range in kPag/min is 0.0007 to 62.0500.</p> <p>High Pressure sample chamber:</p> <p>The range in psig is 0.001 to 99 minimum (the default is 0.05)</p>
<b>Interval Time: (Does not display for Equilibrate)</b>	<p>Select the <i>Fixed interval</i> at the <i>P1, P2 end by?</i> prompt. Pressure measurement ends when the specified time is reached. Key in the interval time.</p> <p>The range is 10 to 99999 seconds.</p>

Display Text	Description
<b>Use Run Precision?</b>	<p>Allows early termination of the analysis when certain criteria are met.</p> <ul style="list-style-type: none"> <li>■ <b>Yes.</b> The analysis terminates after five consecutive cycles are within the specified tolerance. Always request a large number (50 to 99) of runs. The number of runs is determined through the <i>Number of Cycles</i> option. With a small number of runs, the analysis stops when the selected number is reached, even if the specified tolerance has not been met.</li> <li>■ <b>No.</b> <i>Run Precision</i> is not used.</li> </ul>
<b>Percent Full Scale:</b>	<p>This prompt only displays if <b>Yes</b> is selected for <i>Run Precision</i> and more than five cycles have been requested.</p> <p>Enter the run precision volume tolerance which is expressed as a percentage of nominal cell volume (sample capacity).</p> <p>The range is 0.01% to 50.00%.</p>

## REVIEW DATA

The *Review* function allows review of and editing of the results of the last operation – analysis or calibration – along with its entered parameters. It is important to review and print the report before starting another operation. Data are no longer available for review on the display when another operation is started; however, data results are saved in the control module and can be reviewed using a web browser.

### Review Data with a Web Browser

Data results for the last five analyses are saved in the control module for each attached unit. These results can be viewed by accessing a web browser. To use this feature, connect to a network.

1. Press **Alt + 2** to access *Setup*. Then press **CHOICE** until *Communications* is displayed.
2. Press **ENTER** to display a prompt showing that the IP Address mode is *DHCP*.



The display may show *Specify*, depending on how the IP address was assigned.

3. Press **ENTER** to view the assigned address on the display. If the address was specified, the display shows *IP Address?* and the entered address. This line is editable since it is specified and not assigned automatically. An assigned address cannot be edited.
4. Make a note of the IP address.
5. Press **Alt + CLEAR** to return to the *Reload* prompt.
6. Access the web browser and type in the IP address.
7. Press **Enter** to display the serial number(s) of the attached unit(s).

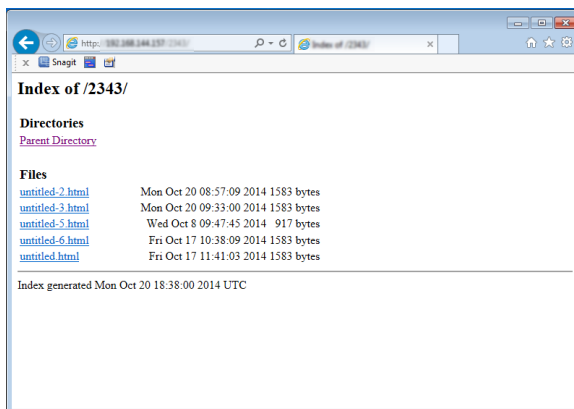

- Click the serial number of the unit containing the data to review. A window displaying the data files for the last five analyses, and for the zero (slope) and volume offset files is displayed.

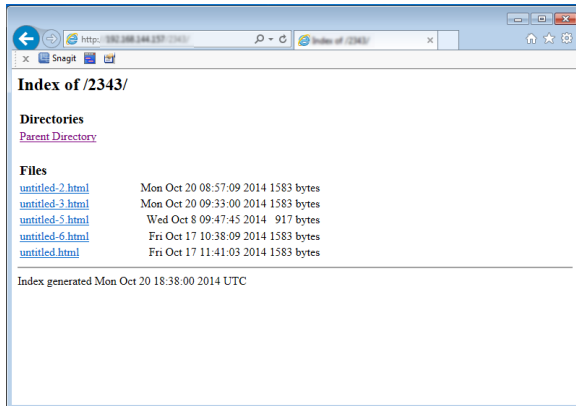

The files are in .HTML format and are assigned the name used as the *Sample ID*. If sample identifications are not used, *Untitled* is assigned and appended for each file.

- Click the file to view the data results. The progress of a current operation can be monitored by reloading the page.

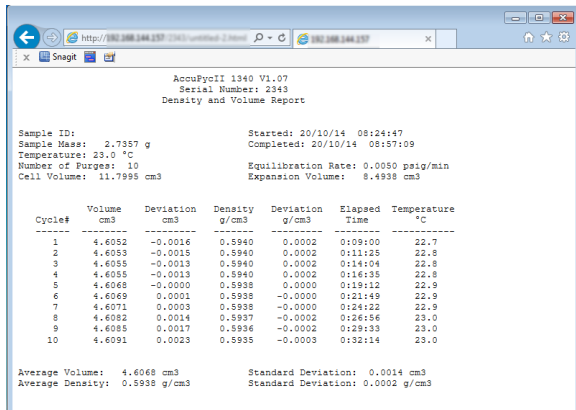

AccuPycII 1340 V1.07  
 Serial Number: 2343  
 Density and Volume Report

Sample ID: Started: 20/10/14 08:24:47  
 Sample Mass: 2.7357 g Completed: 20/10/14 08:57:09  
 Temperature: 23.0 °C  
 Number of Pours: 10 Equilibration Rate: 0.0050 psig/min  
 Cell Volume: 11.7995 cm<sup>3</sup> Expansion Volume: 0.4938 cm<sup>3</sup>

Cycle#	Volume cm <sup>3</sup>	Deviation cm <sup>3</sup>	Density g/cm <sup>3</sup>	Deviation g/cm <sup>3</sup>	Elapsed Time	Temperature °C
1	4.6052	-0.0016	0.5940	0.0002	0:09:00	22.7
2	4.6053	-0.0015	0.5940	0.0002	0:11:25	22.8
3	4.6055	-0.0013	0.5940	0.0002	0:14:04	22.8
4	4.6055	-0.0013	0.5940	0.0002	0:16:35	22.8
5	4.6068	-0.0000	0.5938	0.0000	0:19:12	22.9
6	4.6069	0.0001	0.5938	-0.0000	0:21:49	22.9
7	4.6071	0.0003	0.5938	-0.0000	0:24:22	22.9
8	4.6082	0.0014	0.5937	-0.0002	0:26:56	23.0
9	4.6085	0.0017	0.5936	-0.0002	0:29:33	23.0
10	4.6091	0.0023	0.5935	-0.0003	0:32:14	23.0

Average Volume: 4.6068 cm<sup>3</sup> Standard Deviation: 0.0014 cm<sup>3</sup>  
 Average Density: 0.5938 g/cm<sup>3</sup> Standard Deviation: 0.0002 g/cm<sup>3</sup>

- Use the *File > Print* option to print the results.

## VIEW DATA RESULTS

Press **Alt + 5** to view data results.

Reports are generated after analysis and calibration, and remain available for viewing or printing until another automatic operation (other than zero) is performed. When an automatic operation is performed, data from the previous operation are no longer available for viewing on the display.

A display report is always generated regardless of the specified destination and contains:

- **Analysis.** The average density (or volume) and the deviation from the mean.
- **Calibration.** Average cell volume (or expansion volume) and the deviation from the mean.

## PRINT A FILE



Contact Micromeritics Customer Service for information on supported printers.

Press **Alt + 6** to print a report of the last operation; analysis or calibration. If **Alt + 6** is pressed during an automatic operation, a partial report is printed.

Reports are generated after analysis and calibration, and remain available for viewing or printing until another automatic operation (other than zero pressure) is performed. Previously generated reports are deleted whenever a new automatic operation begins.

For each attached analysis module, the data for up to five analyses are stored in the control module. These data sets can be viewed using a web browser when connected to a network.

An asterisk next to a cycle number indicates that it has not been included in calculations.

- **Analysis.** Volume, density, deviation for each cycle, an average of all cycles, the date and time the analysis was started and completed, and the temperature of the cell chamber.
- **Calibration.** Cell and expansion volumes and deviations for each cycle, an average of all cycles, and the date and time the calibration started and completed.

**Blank Page**

---



## 3 ABOUT THE SOFTWARE

---

- [Software in 21CFR11 Environments on page 3 - 19](#)

The AccuPyc II Pycnometer's unique *run precision* reports data from five consecutive runs that are within a user-specified tolerance. This feature allows early termination of analyses, thereby decreasing the number of runs needed for accurate results.

Analysis provides the measurement of sample volume, from which density can be derived automatically if the sample mass is entered. The unit comes preprogrammed with default conditions and ready to perform analyses. It can be reprogrammed to meet specific needs. Analyses can be modified by entering the number of purges and purge fill pressure, number of cycles and cycle fill pressure, equilibration rate, and run precision. Modifying these parameters allow control of the primary portions of the analysis; purge and run.

When the PC software is not running, the AccuPyc II can be operated in keypad mode. For example; if the computer is inoperative, analyses can be performed using the keypad.

If running the FoamPyc module, an option to select a Standard method is available so that analyses on other types of sample materials can be performed.

### MENU STRUCTURE

All program functions use standard Windows menu functionality. The title bar contains a *Unit [n]*. If multiple analyzers are installed, ensure the appropriate unit is selected before continuing.

#### Main Menu Bar Options

Option	Description
<b>File</b>	Use to manage files used by the application — such as sample files, analysis conditions files, report options files, etc.
<b>Unit [n]</b>	Use to perform analyses, calibrations, and other analyzer operations. <i>Unit [n]</i> displays on the menu bar for each analyzer attached to the computer.
<b>Reports</b>	Use to run reports and view the results.
<b>Options</b>	Use to edit the default method, specify system configuration, specify units, and change presentation options.
<b>Window</b>	Use to manage open windows and display a list of open windows. A checkmark appears to the left of the active window.
<b>Help</b>	Provides access to the embedded operator manual, the Micromeritics web page, the analyzer web page, and information about the application.

## COMMON FIELDS AND BUTTONS

The fields and buttons in the following table are located in multiple windows throughout the analyzer application and have the same description or function. Fields and button descriptions not listed in this table are found in tables in their respective sections.

### Common Fields and Buttons

Field or Button	Description
<b>Add</b>	Add an item to the list.
<b>Add Log Entry</b>	Use to enter information to appear in the sample log report that cannot be recorded automatically through the application. Click the button again to enter multiple log entries.
<b>Append</b>	Use to insert one row at the end of a table.
<b>Autoscale</b>	When enabled on report parameters windows, allows the x- and y-axes to be scaled automatically. <i>Autoscale</i> means that the x- and y- ranges will be set so that all the data is shown. If <i>Autoscale</i> is not selected, the entered range is used.
<b>Axis Range</b>	On report parameters windows, the <i>From / To</i> fields are enabled when <i>Autoscale</i> options are not selected. Enter the starting and ending values for the x- and/or y-axes.
<b>Bar Code</b> ( <i>default field label name</i> )	Enter bar code reader information if a bar code reader is connected to the computer's USB port. If a bar code reader is not used, this alpha-numeric field can be used to enter additional information about the sample, such as a sample lot number, sample ID, etc.
<b>Browse</b>	Searches for a file.
<b>Cancel</b>	Discards any changes or cancels the current process.
<b>Clear</b>	Use to clear the table entries and display only one default value.
<b>Close</b>	Closes the active window.
<b>Close All</b>	Closes all active windows. If changes were made and not yet saved, a prompt displays for each changed file providing the option to save the file.
<b>Comments</b>	Enter comments about the sample or analysis. Comments display in the report header.
<b>Copies</b>	Select the number of copies to print. This field is only enabled when <i>Print</i> is selected.
<b>Delete</b>	When working with pressure tables and pressures, <b>Delete</b> removes the selected information.
<b>Destination</b>	Select the report destination.
<b>Edit</b>	When working with report parameters, highlight the item in the <i>Selected</i>

## Common Fields and Buttons (continued)

Field or Button	Description
	<i>Reports</i> list box and click <b>Edit</b> to modify the report details.
<b>Exit</b>	Exits the application. If a file is open with unsaved changes, a prompt displays providing the option to save the changes and exit or to exit the application without saving the changes.
<b>Export</b>	Exports data in a sample file as a .REP, .TXT, or .XLS file. When saved to a file, the data can be imported into other applications.
<b>File</b>	Select the destination directory. Enter a new file name in the <i>File name</i> field, or accept the default. Select to save the file as a report system (.REP), a spreadsheet (.XLS), a portable document format (.PDF), or an ASCII text (.TXT) file format.
<b>File name</b>	Select a file name from the list shown or enter a file name. If the required file type is not shown, select the type of file from the list.
<b>From / To</b>	When working with report parameters windows, enter the <i>From</i> and <i>To</i> range for x- and/or y-axes.
<b>Insert</b>	Use to insert one row above the selected row in the table.
<b>List</b>	Creates a list of sample or other type files. The list will contain file name, date / time the file was created or last edited, file identification, and file status.
<b>Name</b>	The <i>Name</i> column is a list of files in the selected directory or library.
<b>Next</b>	Click to move to the next window or next step.
<b>OK</b>	Saves and closes the active window.
<b>Open</b>	Opens the selected file. Alternatively, double click the file name in the <i>Name</i> column to open the file.
<b>Prev</b>	Click to move to the previous window.
<b>Preview</b>	Previews predefined reports. Click the tabs at the top of the window to preview each selected report. When an analysis has not been run on a sample, this button is disabled.
<b>Print</b>	Sends the report to the selected destination (screen, printer, or file).
<b>Remove</b>	Remove the selected file or files from the list.
<b>Replace</b>	Click to select another file where the values will replace the current file's values.
<b>Replace All</b>	Click to select another .SMP file where the values will replace all values for the active sample file. The original file will remain unchanged.
<b>Report</b>	Click to display a window to specify report output options.
<b>Save</b>	Saves changes.

---

**Common Fields and Buttons (continued)**

<b>Field or Button</b>	<b>Description</b>
<b>Save As</b>	Saves a file in the active window under a different file name.
<b>Start</b>	Starts the report, test, analysis, or operation.
<b>Start Date</b>	Displays a calendar to select the start date for the report.
<b>View</b>	<p><b>Operation.</b> Use to display the data from the current analysis.</p> <p><b>Instrument Log.</b> Use to display recent analyses, calibrations, errors, or messages.</p> <p><b>Instrument Schematic.</b> Use to display a schematic of the analyzer system.</p>

## OPTION PRESENTATION

### Options > Option Presentation

#### CFR Note

For 21CFR11 environments, see [Option Presentation in 21CFR 11 Environments](#).

Use to change the way sample files and parameter files display: *Advanced*, *Basic*, or *Restricted*. Each display option shows sample information and options differently.

#### Option Presentation Display

Presentation Display	Description
<b>Advanced</b>	Displays all parts of sample and parameter files. Navigate to parameter windows by selecting the tabs across the top of the window.
<b>Basic</b>	Displays sample information in a single window. This display option is used after the parameter files have been created. The previously entered or default parameter files are then accessible using drop-down lists.
<b>Restricted</b>	Displays the sample file in a single window similar to the <i>Basic</i> display option with certain functions disabled. A password is set when the <i>Restricted</i> option is selected. That same password must be entered to change to the <i>Basic</i> or <i>Advanced</i> display option. This display type is typically used in laboratories where analysis conditions must remain constant — such as the pharmaceutical industry. The <i>Advanced</i> option is not available in the view selector at the bottom of the window when using the <i>Restricted</i> display option.
<b>Always Open Edit View</b>	Opens files with a <i>Complete</i> status in tabbed file editor rather than in the editor view.
<b>Show Cup Properties</b>	Enable to show the cup properties for a pycnometry analyzer.
<b>Show Asphalt Options</b>	Enable to show the asphalt properties for a pycnometry analyzer.
<b>Show Splash Screen</b>	Enables (or disables) the splash screen upon application startup.



To change the view for the selected window, use the drop-down list at the bottom of the sample file editor.

The following examples show the same sample file in *Advanced* and *Basic* display. *Basic* and *Restricted* displays will look the same. A password is required if using *Restricted* format.

### Option Presentation Examples

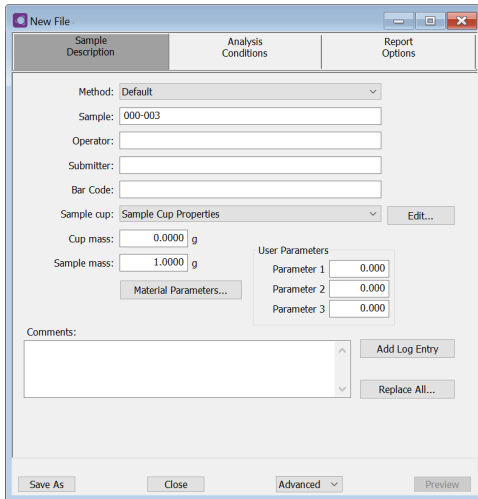

The 'Advanced view' of the 'New File' dialog box shows a detailed configuration interface. It includes tabs for 'Sample Description', 'Analysis Conditions', and 'Report Options'. The 'Sample Description' tab is active, showing fields for Method (Default), Sample (000-003), Operator, Submitter, Bar Code, Sample cup (Sample Cup Properties), Cup mass (0.0000 g), and Sample mass (1.0000 g). There is also a 'User Parameters' section with three parameters set to 0.000. A 'Comments' text area and 'Add Log Entry' and 'Replace All...' buttons are also present. The bottom of the dialog has 'Save As', 'Close', 'Advanced' (dropdown), and 'Preview' buttons.

**Advanced view**

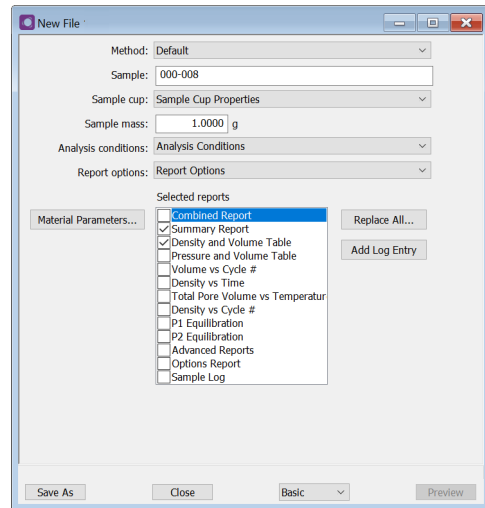

The 'Basic or Restricted view' of the 'New File' dialog box shows a simplified configuration interface. It includes fields for Method (Default), Sample (000-008), Sample cup (Sample Cup Properties), and Sample mass (1.0000 g). The 'Analysis conditions' and 'Report options' are set to 'Analysis Conditions' and 'Report Options' respectively. A 'Selected reports' list is shown with checkboxes for various report types, including 'Combined Report', 'Summary Report', 'Density and Volume Table', 'Pressure and Volume Table', 'Volume vs Cycle #', 'Density vs Time', 'Total Pore Volume vs Temperatur', 'Density vs Cycle #', 'P1 Equilibration', 'P2 Equilibration', 'Advanced Reports', 'Options Report', and 'Sample Log'. 'Replace All...' and 'Add Log Entry' buttons are also present. The bottom of the dialog has 'Save As', 'Close', 'Basic' (dropdown), and 'Preview' buttons.

**Basic or Restricted view**



A sample file must be created for each analysis. The file can be created prior to or at the time of analysis. The sample file identifies the sample, guides the analysis, and specifies report options.

## FILE STATUS

In the *File Selector* window, the *Mic Description* column and the *Mic Status* column display file description and file status. The *File Selector* incorporates standard Windows features for resizing windows, reordering and repositioning columns, and right clicking an entry to display a menu of standard Windows functions.

### File Status

File Status	Description
Analyzing	Sample files that are currently being used for analysis.
Complete	Sample files used in an analysis that has been completed.
No Analysis	Sample files which have not been used to perform an analysis.

### File Type, File Name Extension, File Location

File Type	File Name Extension
Analysis Conditions	.ANC
Methods	.MTH
Report Options	.RPO
Sample Cup	.CUP
Sample Information	.SMP
SPC Report	.SPC

### File Types for Printing or Exporting

File Type	File Name Extension
Spreadsheet	.XLS
Unicode	.TXT

## KEYBOARD SHORTCUTS

Shortcut keys can be used to activate some menu commands. Shortcut keys or key combinations (when applicable) are listed to the right of the menu item.

Certain menus or functions can also be accessed using the **Alt** key plus the underlined letter in the menu command. For example:

- to access the *File* menu, press **Alt + F**, then press the underlined letter on the submenu
- **Alt + F** opens the *File* menu, then press **O** to access the *File Selector*



If the underscore does not display beneath the letter on the menu or window, press the **Alt** key on the keyboard.

### Keyboard Shortcuts

Field or Button	Description
<b>Alt + F</b>	Opens the <i>File</i> menu.
<b>Alt + F4</b>	Exits the program. If files are open with unsaved changes, a prompt to save changes displays.
<b>Alt + H</b>	Opens the <i>Help</i> menu.
<b>Alt + I</b>	Opens the <i>Options</i> menu.
<b>Alt + R</b>	Opens the <i>Reports</i> menu.
<b>Alt + W</b>	Opens the <i>Window</i> menu.
<b>Ctrl + N</b>	Opens a new sample file.
<b>Ctrl + O</b>	Opens the <i>File Selector</i> window.
<b>Ctrl + P</b>	Opens the <i>File Selector</i> to start a report from a selected .SMP file.
<b>Ctrl + S</b>	Saves the open file.
<b>F1</b>	Opens the online help operator manual.
<b>F2</b>	Opens the <i>File Selector</i> window.
<b>F3</b>	When in the <i>File Selector</i> window, opens the file search box.
<b>F5</b>	Opens the <i>File Selector</i> window listing report options files.
<b>F6</b>	Cascades open windows.
<b>F7</b>	Tiles all open application windows.
<b>F8</b>	Opens the <i>File Selector</i> to start a report from a selected .SMP file.



### Keyboard Shortcuts (continued)

Field or Button	Description
F9	Closes all open reports.
Shift + F2	Opens the <i>File Selector</i> window listing sample information files.

## ***DEFAULT METHODS***

### ***Options > Default Method***

A *Default Method* determines the default sample identification format and sequence number. A *Default Method* is a template of specifications that go into a newly created sample file. It allows for the definition of complete sets of parameters for each type of sample commonly analyzed, so that only a single selection is required for each new sample file created.

The initial contents for new sample and parameter files come from the default method. The default method can be edited like other sample files. The default method's **Replace All** button can be used to set the defaults from an existing sample file.

## ANALYZER STATUS

### SHOW INSTRUMENT LOG

#### Unit [n] > Show Instrument Log

Use to display a log of recent analyses, calibrations, errors, or messages.

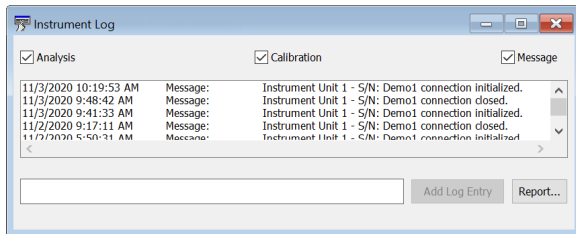

### Instrument Log

Field or Button	Description
<b>Add Log Entry [button]</b>	Use to enter information to appear in the sample log report that cannot be recorded automatically through the application. Click the button again to enter multiple log entries.
<b>Analysis/ Calibration/ Message [checkbox]</b>	Select the logs to display.
 <p>For fields and buttons not listed in this table, see <a href="#">Common Fields and Buttons on page 3 - 2</a>.</p>	

## SHOW INSTRUMENT SCHEMATIC

### Unit [n] > Show Instrument Schematic

Use to display an analyzer schematic. To operate the valves and elevator from this window, manual control must be enabled (**Unit [n] > Enable Manual Control**).

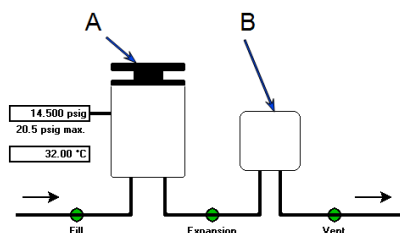
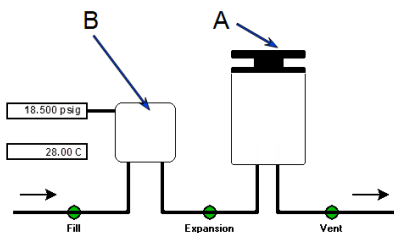

 10, 100, and 350 cm<sup>3</sup> unit

 1 and 2000 cm<sup>3</sup> unit

- A. Sample chamber
- B. Expansion chamber

## Analyzer Schematic Icons

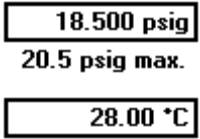
Icon or Symbol	Description
	<b>Open Valve.</b> Green indicates an open valve. <ul style="list-style-type: none"> <li>■ <b>Fill Valve.</b> Allows gas to pressurize the first chamber.</li> <li>■ <b>Expansion Valve.</b> Allows gas from the first chamber to flow into the second chamber.</li> <li>■ <b>Vent Valve.</b> Vents gas from the system.</li> </ul>
	<b>Closed Valve.</b> <ul style="list-style-type: none"> <li>■ Yellow — indicates a closed valve with manual control enabled.</li> <li>■ White — indicates a closed valve with manual control not enabled.</li> </ul>
	<b>Sample Chamber.</b>
	<b>Expansion Chamber.</b>

### Analyzer Schematic Icons (continued)

Icon or Symbol	Description
	<b>Pressure and temperature readings.</b> Displays for either the expansion chamber or the sample chamber, depending on the unit configuration.
	Gas flow direction.

### Instrument Schematic Shortcut Menus

Each manually controlled schematic component has a shortcut menu displaying the operations available for that particular component. To access the shortcut menu, hover the mouse pointer over the component and right click.

#### Schematic Shortcuts

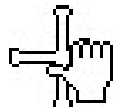
Icon or Symbol	Description
<b>Valve options</b> 	<b>Close.</b> Closes the selected valve.  <b>Open.</b> Opens the selected valve.

## SHOW STATUS

### Unit [n] > Show Status

Use to show the current status for each port. If multiple units are attached to the computer, go to **Unit [n] > Show Status** for the indicated unit.

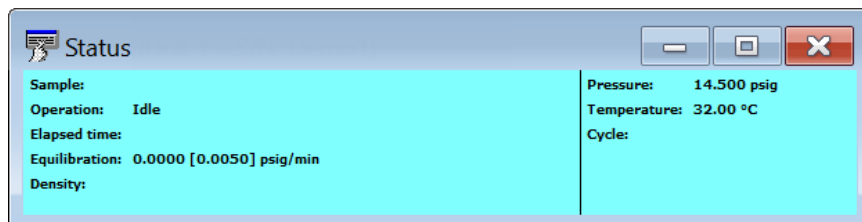

### Show Status

Field or Button	Description
<b>Cycles</b>	The current cycle and the number of cycles requested. For example, 2 (current) of 10 (requested).
<b>Density</b>	Last computed density and standard deviation.
<b>Elapsed Time</b>	The elapsed time of the current step.
<b>Equilibration</b>	The measured equilibration rate and the limit.
<b>Operation</b>	The operation, task, and the step in progress.
<b>Pressure</b>	The pressure in the sample chamber.
<b>Sample</b>	The name of the sample file being analyzed.
<b>Temperature</b>	The temperature of the sample chamber.



For fields and buttons not listed in this table, see [Common Fields and Buttons on page 3 - 2](#).

## EXPORT FILES

### File > Export

- [Exported Data Example on page B - 1](#)

Provides the option to print the contents of one or more sample or parameter files to either the screen, a printer, or to a file. Data can be exported as a .PDF, .REP, .TXT, .XML, or .XLS file format. The type of data to include or exclude can be selected during the export process. When exported to a file, the data can be imported into other applications that read these file formats.

## LIST FILES

### File > List

Provides the option to create a list of sample file information —such as file name, date, time the file was created or last edited, file identification, and file status.

Select one or more files from the file selector, click [List](#), then provide the file destination.

File Listing					
No.	File Name	Date	Time	Description	Status
1	13x with CO2 at 0C Port 1B.SMP	8/10/2020	3:53:54 PM	13x with CO2 Port 1	Complete
2	13x with CO2 at 0C Port 2B.SMP	8/10/2020	3:53:54 PM	13x with CO2 Port 2	Complete
3	13x with CO2 at 0C Port 3B.SMP	8/10/2020	3:53:54 PM	13x with CO2 Port 3	Complete
4	13x with N2 and TranSeal Port 2.SMP	8/10/2020	3:53:54 PM	13X Zeol Tube 2 w/ FS @ end of analysis, Port 2	Complete
5	13x with N2 and TranSeal Port 3.SMP	8/10/2020	3:53:54 PM	13X Zeol Tube 1A w/ FS @ end of analysis, Port 3	Complete
6	Activated Carbon with Butane C3 Port 1.SMP	8/10/2020	3:53:55 PM	Activated Carbon Tube C3 Butane Port 1	Complete
7	Activated Carbon with Butane C4 Port 3.SMP	8/10/2020	3:53:55 PM	Activated Carbon Tube C4 Butane Port 3	Complete

**Example of File List**

## OPEN A SAMPLE FILE

**File > Open > [.SMP File]**

### File Status

File Status	Description
Analyzing	Tabbed file editor.
Complete No analysis	Report window.

If a sample file with a *Complete* status is opened, to review a report, click the report name in the view selector drop-down list at the bottom of the window.

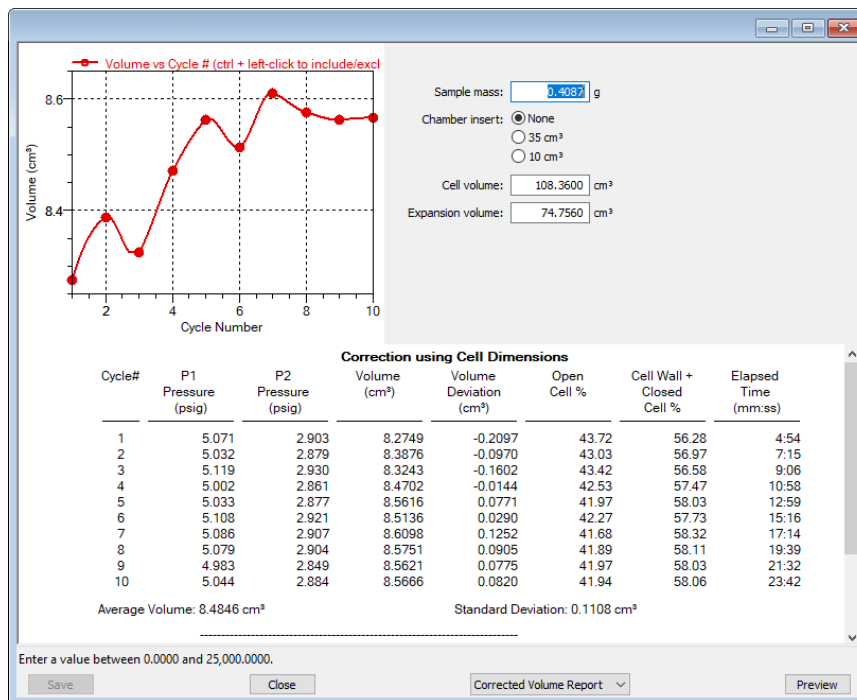

### CFR Note

In 21CFR11 environments, this feature is applicable to members of the Developer group only.

## SOFTWARE UPDATES



User Account Control in the Windows operating system must be enabled to ensure all components of the Micromeritics application are installed properly. If UAC is not enabled, right click the *setup.exe* installer file and select *Run as administrator*.

Log in to your [customer portal](#) to access and download the latest analyzer software version.

When performing a software update, existing data files are not overwritten. There are three types of subsequent installation:

- a later version than the current installation
- the same version as the current installation
- an earlier version than the current installation

Insert the setup media into the media drive. The setup program starts automatically. If the program does not start automatically, navigate to the installation media drive, locate and double click the *setup.exe* file.

### CFR Note

Existing Confirm application users and groups are not affected by software updates. Any changes to Confirm users and Confirm groups must be made using Windows Users and Groups.



---

## ***REINSTALL OR MODIFY THE SOFTWARE***

---



If the computer is to be connected to a network, a second Ethernet port on the computer must be used for that purpose.

---

The *Setup* program is located on the installation media. After initial software installation, if changes need to be made to the analyzer setup, reinsert the *Setup* media and follow the prompts.

- Reinstall the software version [*n*]
- Add an analyzer
- Move an analyzer
- Remove an analyzer
- Change analyzer setup
- Reinstall calibration files for an analyzer
- Uninstall
- Reset security to default

To access the *Setup* program:

1. Insert the *Setup* media into the media drive.
  2. Locate and double click the *Setup.EXE* file.
- 



If the IP address needs to be changed on the computer connected to the analyzer, refer to the computer's operating system manual or the internet for instructions. The IP address for the computer and the IP address specified in the setup program must match. The IP address must be 192.168.77.100.

---

## SOFTWARE UNINSTALL

- [Uninstall Software in 21CFR11 Environments on page 3 - 23](#)

### UNINSTALL THE SOFTWARE USING THE COMPUTER

When the software is uninstalled using *uninstall.exe*, only the files required to run the application are removed. Parameter files, sample files, reports, calibration files, and data files are not removed.

To uninstall the software, double click the *uninstall.exe* file located in the software installation directory, then follow the prompts.

### UNINSTALL THE SOFTWARE USING THE KEYPAD

1. Insert the *Setup* media into the media drive.
2. Select the *Uninstall* option.
3. Follow the prompts.

## UNIT SELECTION

### Options > Units

Use to specify how data should appear on the application windows and reports. This menu option is not available if using *Restricted* option presentation in a standard installation environment.

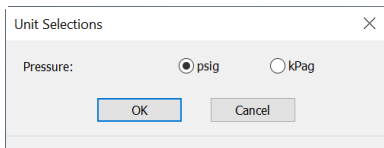

**Standard**

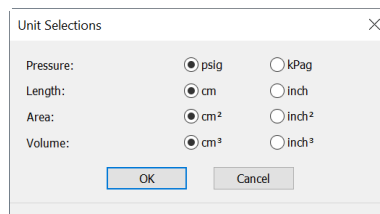

**FoamPyc**

## SOFTWARE IN 21CFR11 ENVIRONMENTS



The Micromeritics Confirm applications for 21CFR11 environments require an operating system of Windows 10 Professional or Windows 10 Enterprise or higher. Management of users and groups is performed in Windows Users and Groups.

The Micromeritics Confirm application enables laboratory managers to develop analysis methods, enforce industry standards, and produce audit trails. It also enables laboratory analysts to perform analyses and produce reports.

### USER PERMISSIONS

Confirm User Name	Description
<b>mic_[<i>analyzer model number</i>]_controller</b>	<p>mic_[<i>analyzer model number</i>]_controller is the user name used by all installations.</p> <ul style="list-style-type: none"> <li>■ This user should have complete control over the installation directory.</li> <li>■ The application is launched under this user name and has this user's privileges to the windows file system.</li> <li>■ This user should not be used by anyone or any other software that is not a Micromeritics application.</li> <li>■ The system administrator has the option of modifying this account so that the password never expires. Alternatively, if the password does expire while the application is running, the application automatically changes the password for this account.</li> </ul>

Confirm Group Name	Description
<b>Developer Group</b>	<p>The default Developer group name is <i>mic_[analyzer model number]_developer</i>. Members of the Developer group:</p> <ul style="list-style-type: none"><li>■ have rights to all functions of the Micromeritics application - including Advanced option presentation which allows the creation and modification of methods, sample files, and parameter files.</li><li>■ can run an analysis.</li><li>■ can also be assigned Administrator rights which control the user profiles.</li></ul>
<b>Analyst Group</b>	<p>The default Analyst group name is <i>mic_[analyzer model number]_analyst</i>. Members of the Analyst group:</p> <ul style="list-style-type: none"><li>■ have access to the Basic presentation option only.</li><li>■ may create sample files from pre-defined methods and can modify only a limited number of input fields.</li></ul>

## OPTION PRESENTATION FOR 21CFR11 ENVIRONMENTS

### Options > Option Presentation

#### Option Presentation Display

Presentation Display	Description
<b>Advanced</b>	Displays all parts of sample and parameter files. Navigate to parameter windows by selecting the tabs across the top of the window.
<b>Basic</b>	Displays sample information in a single window. This display option is used after the parameter files have been created. The previously entered or default parameter files are then accessible using drop-down lists.
<b>Show Cup Properties</b>	Enable to show the cup properties for a pycnometry analyzer.
<b>Show Asphalt Options</b>	Enable to show the asphalt properties for a pycnometry analyzer.
<b>Show Splash Screen</b>	Enables (or disables) the splash screen upon application startup.

#### CFR Note

**For members of the Developer group only.** To change the view from *Advanced* (for Developers) to *Basic* (for Analysts), click the view selector drop-down list at the bottom of the window. Select either *Advanced* (when in *Basic* view) or *Basic* (when in *Advanced* view).

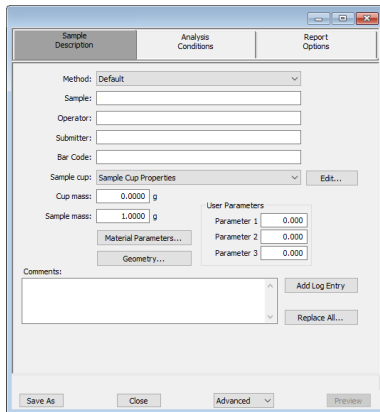

**Example of Developer view**

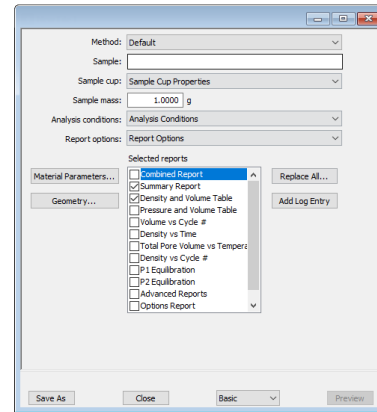

**Example of Analyst view**

### CFR Note

A sample file must be created for each analysis. The file can be created prior to or at the time of analysis. The sample file identifies the sample, guides the analysis, and specifies report options.

The **Save** button is disabled on sample files with a *Complete* status. When the **Preview** button is used to view reports for sample files with an unsaved status, the report will have a *Preview* watermark. The **Save As** and **Print** buttons on the report window are also disabled.

## CREATE A NEW FOLDER

### File > Create New Folder

Provides the option to create and name a new folder in the Confirm application folder. This option may not be available depending on how the IT administrator configures Windows permissions.

## SYSTEM AUDIT TRAIL

### File > System Audit Trail

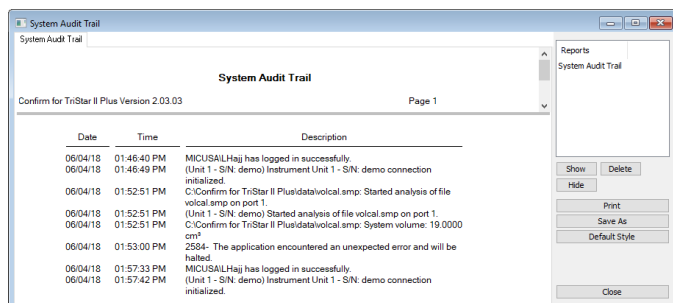

Lists the current user, successful and failed application user login attempts, and contains a description of all the changes made to sample files.

Contains an audit trail of all system initializations, user login attempts, and sample analyses.

## UNINSTALL SOFTWARE IN 21CFR11 ENVIRONMENTS

When the software is uninstalled using *uninstall.exe*, only the files required to run the application are removed. Parameter files, sample files, reports, calibration files, and data files are not removed.

To uninstall the software, double click the *uninstall.exe* file located in the software installation directory, then follow the prompts.

### CFR Note

To uninstall the Micromeritics Confirm application, the owner of the application directory and its contents must be set to the account of the administrator that is removing the application installation. This account must also have permission to modify the application directory and its contents. This may require modification to the owner and to the access permissions of the application directory and its contents.

Upon uninstalling the Confirm application, the system administrator should go into Windows Users and Groups to remove the Confirm users and groups. See the Confirm Administrator Guide [part number 004-42821-01].

Depending on the network, Windows may not allow the *uninstall.exe* program to run. If this happens, follow these steps:

1. In Windows Users and Groups, verify that the current user is not a member of the analyst group or developer group. If so, remove the user from the group(s). Log OFF, then log back ON to the computer.
2. In Windows Explorer, in the Confirm installation directory, double-click the *uninstall.exe* file to run the uninstall program.

**Blank Page**

---



## 4 SAMPLE FILES

---

- [Option Presentation on page 3 - 5](#)
- [Software in 21CFR11 Environments on page 3 - 19](#)

Sample files include the information required by the analyzer to perform analyses and collect data. A sample file identifies the sample, guides the analysis, and specifies report options and may be displayed in either *Advanced*, *Basic*, or *Restricted* presentation display mode.

A sample file consists of parameter sets; however, parameter sets can also stand alone. A sample file may be created either prior to or at the time of analysis.

Parameter files allow for repeated use of parameter sets. For example — if the same analysis conditions exist for multiple analyses, an *Analysis Conditions* file containing the recurring conditions can be created. When the sample file is created, the *Analysis Conditions* file can be selected for the analysis conditions. Once it becomes part of the new sample file, the new file can be edited as needed without affecting the original *Analysis Conditions* file.

The analysis application contains a default method. A method is a template for sample files that contains the parameters to be used for an analysis. When a new sample file is created, all the parameters are filled with the values in the default method.



To change the view for the selected window, use the drop-down list at the bottom of the sample file editor.

### CREATE SAMPLE FILES

**Options > Option Presentation > [Advanced / Basic / Restricted]**

**File > New Sample > [.SMP File]**

**File > Open > [.SMP File]**

#### CFR Note

For 21CFR11 environments, this section is applicable only to members of the Developer group, however, members of the Analyst group may find information in this section helpful. Sample file information that is available to Analysts is created by a member in the Developer group using information in this section.

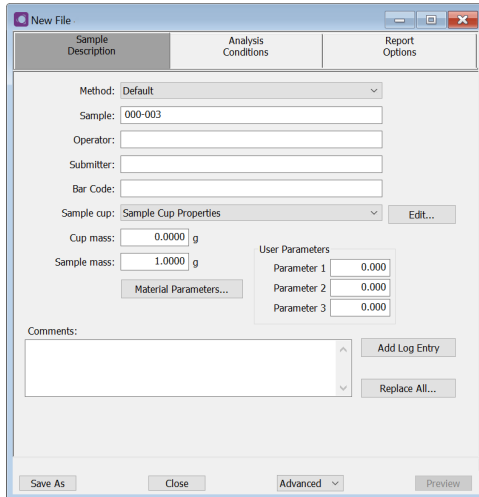

### Example of a Pycnometer Sample File

Each analysis must be linked with a sample file before the analysis can proceed. A sample file can consist of parameter files; however, parameter files can also stand alone. See [Parameter Files on page 5 - 1](#).

The values specified in the parameter portions of the default sample file are saved as the defaults for new sample files. To navigate from one set of parameters to another, select the parameter tab across the top of the window.

The *Basic* and *Restricted* formats use predefined parameter files to create a sample file.



When using the *Basic* option presentation, switch to *Advanced* to edit parameter file values. When using the *Restricted* option presentation, parameter files cannot be edited.



A bar code reader may be used to enter text into many of the fields on the *Sample Description* window. Use a mouse to click in the field first where information is to be entered then scan the bar code with the bar code reader

## Sample Files for Pycnometry Analyzers

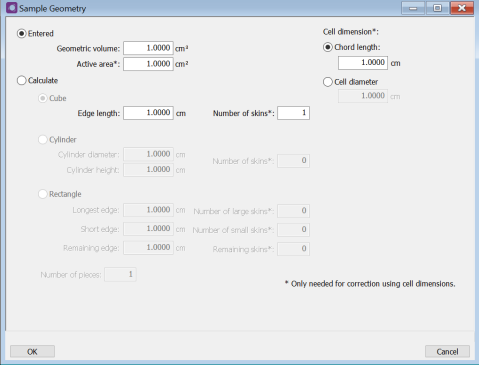
Field or Button	Description
<b>Cup mass</b> [text box]	Displays when <i>Show Cup Properties</i> in option presentation is enabled. Enter the cup mass.
<b>Geometry</b> [button]	<p>Enter material properties when using the FoamPyc application.</p>  <p><b>Entered.</b> Select to enter the geometric volume and when using <i>Correction using cell dimensions</i> selection. The <i>Active Area</i> is the total geometric surface area of the sample - excluding any sides that contain a skin.</p> <p><b>Calculate.</b> Select the shape of the sample and enter the dimensions.</p> <p><b>Number of Pieces.</b> The number of pieces making up the sample.</p>
<b>Material Parameters</b> [button]	See <a href="#">Material Parameters on page 4 - 6</a> .
<b>Operator</b> [text box]	Enter operator identification information. This field label may have been renamed or may not display if modified in <b>Options &gt; Default Method</b> .
<b>Sample</b> [text box]	Enter a sample description.
<b>Sample cup</b> [drop-down box]	Displays when <i>Show Cup Properties</i> in option presentation is enabled. Select a sample cup file from the drop-down list or click <b>Edit</b> to create and save a new file for sample cup properties. See <a href="#">Sample Cup on page 4 - 5</a> .

### Sample Files for Pycnometry Analyzers (continued)

Field or Button	Description
<b>Sample mass</b> [text box]	Enter the sample mass.
<b>Submitter</b> [text box]	Enter submitter identification information. This text box may have been renamed or may not display if modified in <b>Options &gt; Default Method</b> .
<b>User Parameters</b> [group box]	These fields are primarily used for the SPC (Statistical Process Control) reporting to specify sample characteristics or its manufacturing process but may be used for other data by entering specific analysis conditions or sample criteria. The entered parameters display on the <i>Summary Report</i> . This option may not display (or may have a different field label) if modified in the through <b>Options &gt; Default Method</b> .
 <p>For fields and buttons not listed in this table, see <a href="#">Common Fields and Buttons on page 3 - 2</a>.</p>	

## SAMPLE CUP

**Options > Option Presentation > Show Cup Properties  
File > Open > [.CUP File]**

(or click the *Sample Description* tab when in Advanced option presentation)

Use to set the sample cup mass and density.

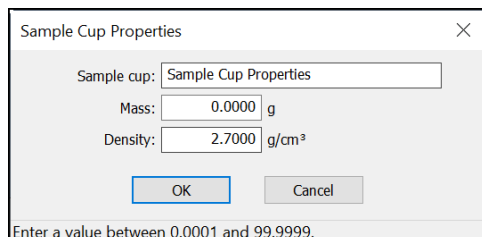

### Sample Cup Properties for Pycnometry Analyzers

Field or Button	Description
<b>Density</b> [text box]	Enter the density of the sample cup.
<b>Mass</b> [text box]	Enter the sample cup mass.
<b>Sample Cup</b> [text box]	Enter a description of the sample cup.
 <p>For fields and buttons not listed in this table, see <a href="#">Common Fields and Buttons on page 3 - 2</a>.</p>	

## MATERIAL PARAMETERS

**File > Open > [.SMP File]**

Material parameters are used to report porosity or total solids concentration when using the *Standard* analysis method.

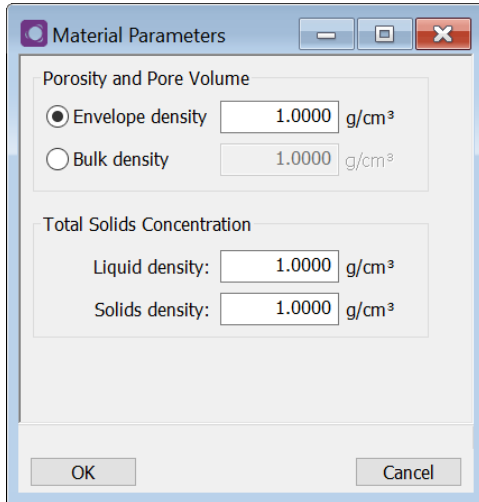

### Material Parameters for Pycnometry Analyzers

Field or Button	Description
<b>Bulk Density / Envelope Density</b> [ <i>selection</i> ]	Calculated from a volume that includes pores.
<b>Liquid Density</b> [ <i>text box</i> ]	Density of the liquid.
<b>Solids Density</b> [ <i>text box</i> ]	Density of the solid sample.
 <b>For fields and buttons not listed in this table, see <a href="#">Common Fields and Buttons on page 3 - 2</a>.</b>	

## 5 PARAMETER FILES

### CFR Note

For 21CFR11 environments, this section is applicable only to members of the Developer group, however, members of the Analyst group may find information in this section helpful. Sample file information that is available to Analysts is created by a member in the Developer group using information in this section.

Parameter files allow for repeated use of parameter sets. For example — if the same analysis conditions exist for multiple analyses, an *Analysis Conditions* file containing the recurring conditions can be created. When the sample file is created, the *Analysis Conditions* file can be selected for the analysis conditions. Once it becomes part of the new sample file, the new file can be edited as needed without affecting the original *Analysis Conditions* file.

The following file types can exist as part of the sample file as well as individual parameter files:

File Type	File Extension
Analysis Conditions	.ANC file extension
Report Options	.RPO file extension
Sample Cup	.CUP file extension

## ANALYSIS CONDITIONS

**File > Open > [.ANC File]**

(or click the *Analysis Conditions* tab when in *Advanced* presentation option)

Analysis conditions specify the parameters used to guide an analysis.

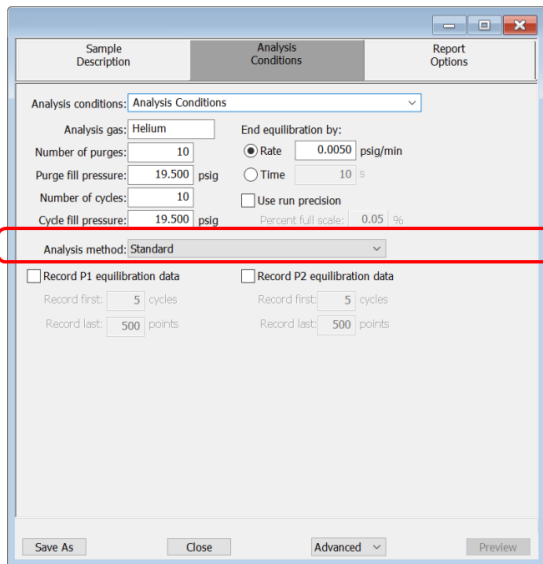

The screenshot shows the 'Analysis Conditions' dialog box with the following settings:

- Analysis conditions: Analysis Conditions
- Analysis gas: Helium
- Number of purges: 10
- Purge fill pressure: 19.500 psig
- Number of cycles: 10
- Cycle fill pressure: 19.500 psig
- End equilibration by: Rate (0.0050 psig/min)
- Time: 10 s
- Use run precision:
- Analysis method: Standard (highlighted with a red box)
- Record P1 equilibration data:  Record first: 5 cycles, Record last: 500 points
- Record P2 equilibration data:  Record first: 5 cycles, Record last: 500 points

**Analysis method is for the FoamPyc application only**

### Analysis Conditions for Pycnometry Analyzers

Field or Button	Description
<b>Analysis Conditions</b> [text box]	Displays the description of the file. If this is a new file, the description specified in default methods is displayed.
<b>Analysis gas</b> [text box]	The gas to be used for analysis gas (helium is recommended).
<b>Analysis method</b> [selection]	<p>For the FoamPyc application only.</p> <ul style="list-style-type: none"> <li> <b>Standard.</b> Select <i>Record equilibration data</i> then enter the criteria (if recording equilibration data). </li> </ul> <p>Enter the cell wall density.</p> <ul style="list-style-type: none"> <li> <b>Correction using cell dimensions.</b> Measures the closed cell fraction and corrects for the cells damaged while cutting the sample to the necessary size and shape. This is accomplished by using either the average cell diameter or the cell chord length (as </li> </ul>



## Analysis Conditions for Pycnometry Analyzers (continued)

Field or Button	Description
	<p>defined in ASTM method D-6226-15) and the measurements of the sample to determine the volume of the cut cells. This volume is deducted from the total volume of the open cells measured by the pycnometer.</p> <ul style="list-style-type: none"> <li>■ <b>Correction by recutting sample.</b> Corrects for the cut cells by using two separate measurements. For the 2nd measurement, the sample is recut to double the amount of cut surface. The observed difference in cut open cell volume is applied as a correction to the initial measured volume. This method offers the distinct advantage that no assumptions are needed about the relative amounts of open and closed cells.</li> <li>■ <b>No correction.</b> Does not correct for cut cells. It is used for materials with predominantly open cells where good accuracy can be achieved without correction. The accuracy level deteriorates as the percentage of closed cells increases.</li> </ul> <p>Enter the initial and final pressure, and the pressure increment.</p> <ul style="list-style-type: none"> <li>■ <b>Compressibility test.</b> The fill pressure is increased incrementally over the sample with each repeat of the P1, P2 cycle (where P1 is the initial pressure to which the sample is charged, and P2 the final pressure after expansion). The apparent variation of the measured sample volume with the average pressure is determined. This test is an approximate indication. It is not intended to be an exact measure of the volume compressibility.</li> </ul> <p>Enter the Low pressure and the Fracture pressure.</p> <ul style="list-style-type: none"> <li>■ <b>Cell fracture test.</b> A perfectly rigid foam is assumed. First, a P1, P2 cycle is performed at the lower of two specified P1 pressures, and the results stored. A second cycle is performed at a higher specified value of P1, then a third cycle identical to the first cycle is performed. The difference between the volume of the sample on the first measurement and on the third measurement is reported as the volume of fractured cells. It is assumed that cells fracture by exposure to the highest pressure (2nd cycle) so that when the third measurement is made, the measured sample volume has decreased from the first cycle by the amount of the closed cell volume which was fractured.</li> </ul>
<b>Cycle fill pressure</b> [text box]	Enter the fill pressure for the cycles. Typically, the default of 19.500 psig is appropriate for most samples.

## Analysis Conditions for Pycnometry Analyzers (continued)

Field or Button	Description
<b>End equilibration by:</b> [ <i>group box</i> ]	<p><b>Rate.</b> Equilibration ends when the rate of pressure change drops below the entered amount.</p> <p><b>Time.</b> Equilibration ends when the specified time interval is attained.</p>
<b>Number of cycles</b> [ <i>text box</i> ]	The number of cycles to be performed. A cycle is a series of functions which equals to a single volume measurement.
<b>Number of purges</b> [ <i>text box</i> ]	The number of purges to be performed. A higher number of purges will mean a cleaner sample.
<b>Percent full scale</b> [ <i>text box</i> ]	Enabled when <i>Use run precision</i> is selected. Enter the run precision volume tolerance which is expressed as a percent of nominal cell volume (sample capacity).
<b>Purge fill pressure</b> [ <i>text box</i> ]	<p>The purge fill pressure (in psig or kPa). For FoamPyc analyses, the typical pressure is 3.5 psig. For analyses on standard samples, the measured volume is more precise if a greater fill pressure is used. The default of 19.500 is appropriate for most standard analyses. Some materials, such as organic polymers, may require a lower pressure in order to limit permeability into the sample matrix.</p> <p>The default is 500 psig for the High Pressure sample chamber.</p>
<b>Record P1 equilibration data</b> [ <i>check box</i> ] <b>Record P2 equilibration data</b> [ <i>check box</i> ]	<p><b>Record first.</b> Enter the number of cycles to be recorded at the beginning of the analysis.</p> <p><b>Record last.</b> Enter the number of points to be recorded at the end of equilibration.</p>
<b>Use run precision</b> [ <i>check box</i> ]	Select to use run precision. This feature provides early termination of the analysis when certain criteria are met. The analysis terminates after five consecutive cycles are within the specified tolerance. Typically, a large number (50 to 99) of cycles is requested. If a small number of runs is selected, the analysis stops when the entered number is reached even though the specified tolerance has not been met. If fewer than five cycles are requested, this feature is disabled.
 <p>For fields and buttons not listed in this table, see <a href="#">Common Fields and Buttons on page 3 - 2</a>.</p>	

## REPORT OPTIONS

**File > Open > [RPO File]**

(or click the *Report Options* tab when in Advanced presentation display)



If using the FoamPyc application, reports for all FoamPyc *Methods* are fixed and cannot be created or selected from within the application.

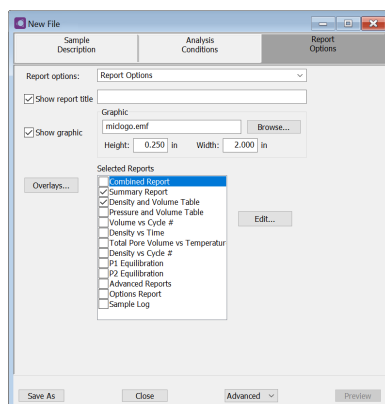

Report options specify the types of reports to be generated from an analysis and allow for customization of reports such as axis scale, axis range, and column headings.

*Report Options* files can be customized to accommodate standard analysis requirements. Reports can be generated automatically after each analysis or at any time during or after an analysis. A report generated during an analysis only includes data collected up to the time of the report.

*Report Options* files may be defined to include overlay options. This system allows the overlay of up to 25 plots of different samples onto a plot of the same type or overlay one plot type onto a different plot type from the same analysis.

### Report Options for Pycnometry Analyzers

Field or Button	Description
<b>Overlays [button]</b>	Click to open the <i>Graph Overlay Samples</i> window. Click <b>Browse</b> to select sample files to overlay into a plot.
<b>Report Options [text box]</b>	Displays the description of the file. If this is a new file, the description specified in default methods is displayed.
<b>Selected Reports [selection]</b>	Select the report names to include in the report.

### Report Options for Pycnometry Analyzers (continued)

Field or Button	Description
<b>Show graphic</b> [check box]	Use to show a graphic on the report header.  <b>Height/Width.</b> Enter the height and width of the selected graphic. These values determine the graphic appearance on the generated report.
<b>Show report title</b> [check box]	Select, then enter a report title to appear on the report header.
	For fields and buttons not listed in this table, see <a href="#">Common Fields and Buttons on page 3 - 2</a> .

---

## 6 PERFORM AN ANALYSIS

---

- [Handling System Components on page 11 - 5](#)

---

### CFR Note

In 21CFR11 environments, users are required to login to the Confirm application to start an analysis. Once the analysis window is opened, manual control is disabled until the analysis has completed. During analysis, pausing and resuming is allowed, however, steps cannot be skipped.

---

An analysis can be performed from either the computer application or directly from the keypad on the analyzer.

## PREPARE AND LOAD A SAMPLE

### FOAMPYC METHODS

- [About the FoamPyc Module on page 1 - 5](#)

FoamPyc Methods are intended to conform to the procedures detailed in ASTM Test Methods D-6226 and D-3576. Prepare samples according to the methods outlined in these procedures. Once the sample is prepared and placed into the sample chamber, analysis can begin.

### STANDARD METHOD

Samples must be properly prepared to obtain accurate results. Samples must be free of moisture in order to obtain true sample mass and to avoid the distorting effect of water vapor on the volume measurement. The following procedures are recommended; however, modifications may be necessary for some materials:

- Heat-sensitive materials may have to be dried by long-time exposure to silica gel, freeze drying, etc.
- Materials having a low melting point may be dried using the purge process. In this case, do not weigh the sample and cup until after the purge and analysis have been completed.

Avoid exposure of the dried sample to atmospheric moisture during each step of the preparation process. This means weighing as rapidly as possible and installing in the instrument without unnecessary delay.



Keep the cap on the cell chamber except when actually inserting or removing a sample. If the chamber remains uncapped, water vapor will adsorb on the inner surface of the chamber and temperature instability will occur; either condition can affect analysis results.

1. Weigh the empty sample cup.
2. Place as large a quantity of sample as is possible in the cup (cup should be at least two-thirds full). Pack powders and fluffy materials (if permissible) to obtain maximum sample weight in the cup.
3. Place the sample cup with sample in a drying oven. The amount of time the sample must be heated depends on the material and the temperature it will tolerate; this may have to be established by other tests.
4. Remove the sample cup from the oven and transfer it to a desiccator provided with active desiccant. Allow it to cool until near room temperature. Minimize air exposure of the sample.
5. Use this equation to determine the sample mass. (If volume only is to be measured, skip this step.)

$$Mass_{\text{sample}} = Mass_{\text{sample+cup}} - Mass_{\text{cup}}$$

6. Remove the cell chamber cap, place the sample cup (with sample) into the cell chamber, then replace the cap.

It is best not to lay the cap down while loading the sample. Immediately replace the cap when the sample is loaded. This will prevent particles from accumulating on the greased surface.

7. If using a temperature-controlled AccuPyc, perform the following steps before proceeding:
  - a. Power on the bath circulator and specify the temperature for analysis. (Refer to the manufacturer manual for instructions on operating the bath circulator.)
  - b. Allow the temperature to stabilize to the set temperature. Observe the temperature reading on instrument schematic.
8. If using a TEC module, ensure the temperature reading has stabilized at the specified point.

## PERFORM AN ANALYSIS USING THE SOFTWARE

### Unit [n] > Sample Analysis

After the sample has been properly prepared and loaded into the sample chamber, start the analysis.

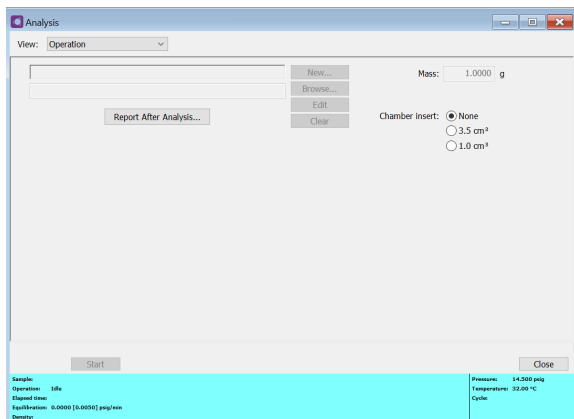

1. Click **New** to create a new sample file or click **Browse** to select an existing file.
2. Click **Report after analysis** to generate reports automatically when the analysis is complete. On the *Report After Analysis Settings* window, select *Report after analysis* and specify a report destination. To export the report, select *Export after analysis* and specify a report destination.
3. Click **OK** to return to the previous window.
4. Ensure the correct *Chamber Insert* is selected.
5. Click **Start** to start the analysis. A window displays data as they are collected. A short delay is encountered before the port status at the bottom of the window changes from the *Idle* state.
6. If running a FoamPyc analysis that requires recutting the sample, a message displays indicating the sample should be cut.
  - a. Remove the sample chamber cap, then remove the sample cup. Replace the cap before performing the next step.
  - b. Cut the sample and return it to the cup.
  - c. Remove the cap, place the cup back into the sample chamber. Replace the cap.
  - d. Click **OK** to complete the second analysis.

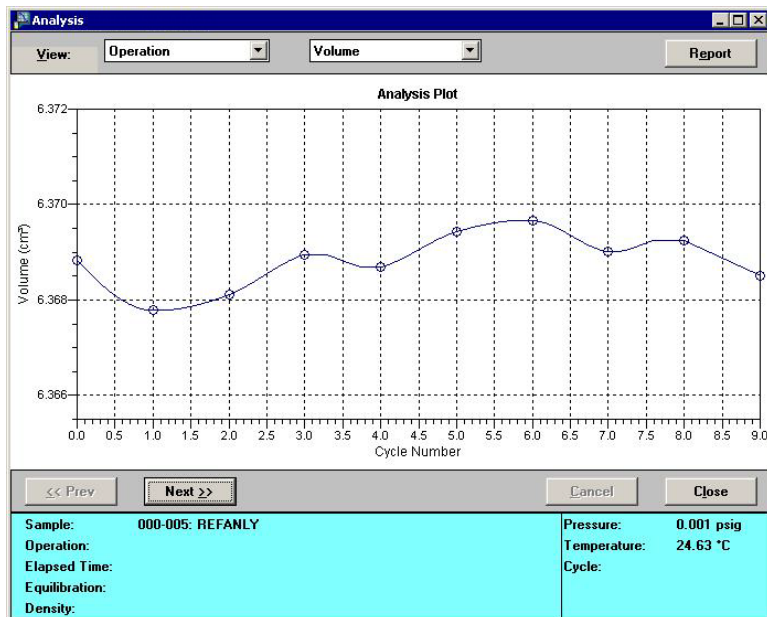



## PERFORM AN ANALYSIS USING THE KEYPAD

Prerequisites:

- Specify analysis and report parameters, and
- Prepare and load sample

1. Press **Alt + 4** to display the *Sample ID* prompt. Enter an appropriate identification. Press **.** (decimal) to insert a dash.
2. Press **ENTER** to display the *Description* prompt.



Most users display this prompt only when a keyboard is attached to the pycnometer.

3. Press **ENTER** to display the *Sample Mass* prompt. Enter the sample mass.
4. If an analytical balance is connected to the module, press the appropriate button on the balance to transfer the sample mass while this prompt is displayed.
5. Press **ENTER** to display the *Chamber Insert* prompt if using an insert. Press **CHOICE** until the appropriate insert is displayed, then press **ENTER**.
6. Press **ENTER** to begin the analysis. Operational status messages display during analysis.
7. When the analysis has finished, the pycnometer beeps three times and the display returns to the *Reload* prompt.



Do not remove the cell chamber cap when the pycnometer is pressurized. The sample may be discharged from the chamber.

8. Ensure the pressure reads approximately 0 (zero), then remove the cell chamber cap and remove the sample from the chamber.
9. Replace the cell chamber cap or load another sample.

Display Text	Description
Analyze Sample ID:	Enter sample identification for the current analysis. Sample ID can be up to 20 numbers and dashes. Press <b>.</b> (decimal) to insert a dash.
Analyze Description Line 1:	Enter the description for the current sample. A prompt for Line 2 of the description is displayed.

Display Text	Description
<b>Analyze Sample Mass:</b>	<p>Enter a value for the sample mass. Displays only when <i>Density</i> is selected for Analysis display mode. It does not display if <i>Volume</i> is selected.</p> <p>The range is 000.0000 to 10000.0000 g.</p> <p>The range for the 2000 cm<sup>3</sup> AccuPyc is 000.0000 to 25000.0000 g.</p> <p>This field will also accept input from a connected analytical balance. While this prompt is displayed, press the appropriate button on the analytical balance to transfer the mass (refer to the manufacturer's manual for the appropriate command).</p>
<b>Analyze Chamber insert?</b>	<p>Select the insert to be used.</p> <ul style="list-style-type: none"> <li>■ None, 0.1 cm<sup>3</sup> (for 1 cm<sup>3</sup> unit)</li> <li>■ None, 3.5 cm<sup>3</sup>, 1.0 cm<sup>3</sup> (for 10 cm<sup>3</sup> unit)</li> <li>■ None, 35 cm<sup>3</sup>, 10.0 cm<sup>3</sup> (for 100 cm<sup>3</sup> unit)</li> <li>■ None, 650 cm<sup>3</sup>, 1300 cm<sup>3</sup> (for 2000 cm<sup>3</sup> pycnometer)</li> </ul> <p>Press <b>CHOICE</b> until the appropriate insert is displayed or <b>None</b> if an insert is not being used.</p>
<b>Analyze Cup Mass?</b>	Enter the mass of the sample cup.
<b>Analyze</b> <b>[ENTER] to start</b> <b>[ESCAPE] to cancel</b>	<p><b>ENTER.</b> Starts the analysis. The analysis begins and operational status messages are continually displayed during analysis</p> <p><b>ESCAPE.</b> Cancels the analysis.</p>
 <p>For keypad and/or keyboard functions or commands not listed in this table, see <a href="#">About the Keypad on page 2 - 3</a>.</p>	

## **QUICKSTART ANALYSIS**

### ***Unit [n] > QuickStart Analysis***

- [\*Perform an Analysis using the Software on page 6 - 3\*](#)

Use to analyze a series of samples of the same type and same analysis conditions. Sample files will be created using selected method.

## SEQUENCE ANALYSIS

### Unit [n] > Sequence Analysis

Use to analyze the same sample using different sample files.

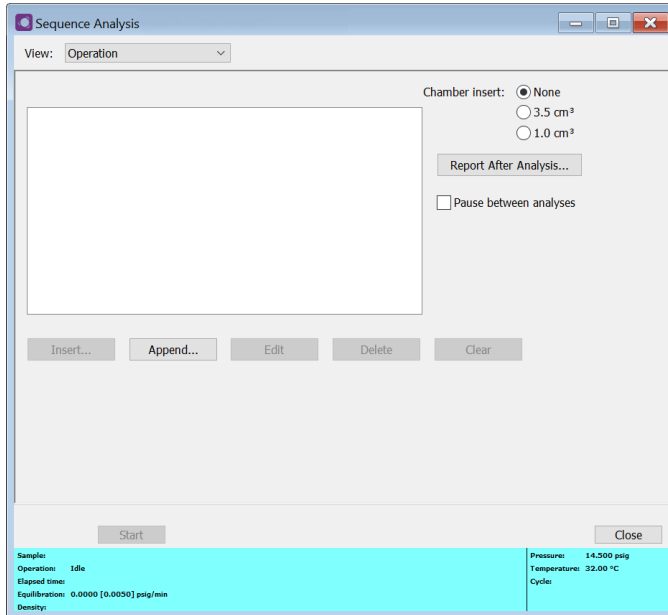

### Sequence Analysis

Field or Button	Description
<b>Chamber Insert</b> [selection]	Select the chamber insert to be used for analysis.
<b>Pause between analyses</b> [checkbox]	When this option is selected, the system will return to the sample selection window after each analysis. Click <b>Start</b> to run the next analysis. As each analysis is run, the sample file is removed from the <i>Samples Files</i> list box.
<b>Report After Analysis</b> [button]	Generates reports automatically to the specified destination when each analysis completes.
	For fields and buttons not listed in this table, see <a href="#">Common Fields and Buttons on page 3 - 2</a> .

## REVIEW ANALYSIS

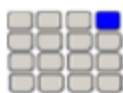

Use these instructions for keypad installations only. If a computer is attached to the module, skip this section. All setup functions will be done in the analysis software.

The *Review* function allows review of the results of the last analysis operation. Press **Alt + 5** to review or edit analysis results. The analysis information can also be edited through the prompts. The prompts that display during the analysis review depend on the options selected in *Setup > Analysis Parameters* and *Report Options*.

1. Press **Alt + 5** to display the *Sample ID* prompt containing the sample identification.
2. Press **ENTER** to display the *Description* prompt containing an additional description. This prompt typically is not used unless a keyboard is connected to the analyzer.
3. Press **ENTER** to display the *Sample Mass* prompt containing the sample's mass.
4. Press **ENTER**. The *Start* prompt containing the start date and time of the analysis is displayed.
5. Press **ENTER**. The *End* prompt containing the ending date and time of the analysis is displayed.
6. Press **ENTER**. The first of the prompts containing data is displayed. The *[n]* displayed in the example prompts represents the cycle number.
7. Continue pressing **ENTER** to view data. Press **CHOICE** to exclude data from report calculations. An asterisk will display indicating that it will be excluded. Press **CHOICE** again to remove the asterisk.
8. Press **SAVE** to return to the *Reload* prompt.
9. Press **Alt + 6** to print report results.

Display Text	Description
<b>Sample ID:</b> (sample identification)	Identification entered for the analysis.
<b>Sample Mass:</b> (mass)	Sample mass for the analysis (if <i>Density</i> was chosen as <i>Analysis</i> display mode).
<b>Temperature:</b> (sample chamber temp)	Sample chamber temperature.
<b>Start:</b> (time) (date)	Time and date the analysis began.  Time: HH:MM:SS Date: DD/MM/YY

Display Text	Description
<b>End:</b> <b>(time) (date)</b>	Time and date the analysis completed.  Time: HH:MM:SS Date: DD/MM/YY
<b>Dn[n] = (density)</b> <b>Dv[n] = (deviation)</b>  <b>or</b>  <b>V[n] = (volume)</b> <b>Dv[n] = (deviation)</b>	Density or Volume (depending on the selection made for Analysis display mode).  <b>[z]</b> : cycle number.  Press <b>CHOICE</b> to exclude the displayed density (or volume) from the calculated average. An asterisk indicates that it has been excluded. Press <b>CHOICE</b> again to remove the asterisk. Each time <b>CHOICE</b> is pressed to exclude (or include) the value, a new deviation is calculated and displayed.  Press <b>SAVE</b> to return to the <i>Reload</i> prompt. Press <b>SAVE</b> to automatically recalculate the collected data and update data reduction messages in the queue.
<div style="display: flex; align-items: center;">  <p>For keypad and/or keyboard functions or commands not listed in this table, see <a href="#">About the Keypad on page 2 - 3</a>.</p> </div>	

## 7 ABOUT REPORTS

---

Review this section for information on the *Reports* menu options as well as customizing and running reports.

Reports can be generated for data:

- collected on a sample that has completed analysis
- collected on a sample currently being analyzed

### **OPEN AND CLOSE REPORTS**

#### ***Reports > Open Report > [.REP File]***

Select one or more .REP files to open, then click **Open**.

#### ***Reports > Close Reports***

Closes all open reports.

### **START REPORTS**

#### ***Reports > Start Report***

Starts the selected report. Select a file from the *Files* list. Ensure the selected file has a status of either *Complete* or *Analyzing*.

## SPC REPORT

### Reports > Open SPC Report

Use to generate reports with various *SPC* (Statistical Process Control) options. All selected variables must be computed for each sample file used in an SPC report; therefore, it is more efficient to select only the necessary variables.

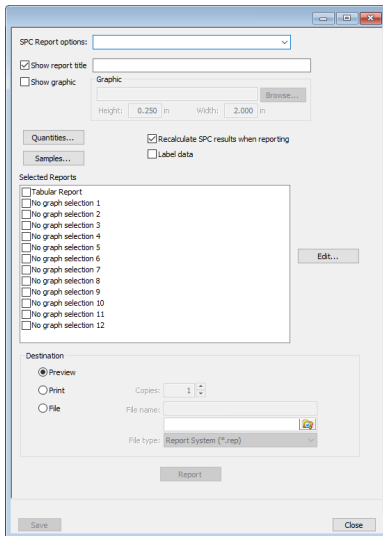

### Example of SPC Report Option

#### SPC Report

Field or Button	Description
<b>AccuPyc / FoamPc</b> [selection]	Select the instrument type.
<b>Edit</b> [button]	Defines the x-axis and y-axis of each graph. Highlight a report in the <i>Selected Reports</i> list box, then click <b>Edit</b> .



## SPC Report (continued)

Field or Button	Description
	<p><b>Regression report.</b> Select to run a Regression report.</p> <p><b>Control chart.</b> Select to run a Control chart report.</p> <p><b>X-Axis.</b></p> <ul style="list-style-type: none"> <li>■ <b>Autoscale.</b> Allows the y-axis to be scaled automatically. To specify a range, deselect this option and enter a range in the <i>From</i> and <i>To</i> fields.</li> </ul> <p>Select the order in which x-axis statistics are placed. Sort by:</p> <ul style="list-style-type: none"> <li>■ <b>Time.</b> Time the files were analyzed.</li> <li>■ <b>File name.</b> Alphanumeric order.</li> <li>■ <b>Date.</b> Date the files were analyzed.</li> <li>■ <b>Minutes.</b> Minutes elapsed from the first file placed on the list, which is the earliest-analyzed file.</li> <li>■ <b>Days.</b> Number of days elapsed from the first file placed on the list, which is the earliest analyzed file.</li> </ul> <p><b>Y-Axis.</b> Click <b>Options</b> to define the control chart graph.</p>

## SPC Report (continued)

Field or Button	Description																																																			
	<ul style="list-style-type: none"> <li>■ <b>Center Line.</b> Displays placement options for the center line in the graph. Select <i>Entered</i> to specify placement of the line or <i>Mean</i> to place the center line at the calculated mean value for the selected samples.</li> <li>■ <b>Limit Lines.</b> Displays limiting lines options. Lines can be placed at some multiple of the standard deviation or at specified positions (<i>Entered</i>). When <i>Entered</i> is selected, enter the <i>High limit</i> and <i>Low limit</i> fields with appropriate values.</li> </ul>																																																			
<b>Label data</b> [ <i>check box</i> ]	Use to label the points on the plot to correspond with the values in the sample files.																																																			
<b>Quantities</b> [ <i>button</i> ]	<p>The selected items display as graph variable selections in the Regression report and the Control Chart report. If report options for NLDFT Advanced PSD are required, click <a href="#">More</a>.</p> <div data-bbox="558 835 938 1423" style="border: 1px solid black; padding: 5px; margin: 10px 0;"> <p style="text-align: center; margin: 0;">AccuPyc SPC Report Quantities <span style="float: right;">×</span></p> <table style="width: 100%; border-collapse: collapse;"> <tr> <td><input type="checkbox"/> Volume</td> <td><input type="checkbox"/> Std.Dev</td> <td><input type="checkbox"/> C.V.</td> </tr> <tr> <td><input type="checkbox"/> Density</td> <td><input checked="" type="checkbox"/> Std.Dev</td> <td><input type="checkbox"/> C.V.</td> </tr> <tr> <td><input checked="" type="checkbox"/> Specific gravity</td> <td><input type="checkbox"/> Std.Dev</td> <td><input type="checkbox"/> C.V.</td> </tr> <tr> <td><input checked="" type="checkbox"/> Total pore volume</td> <td><input type="checkbox"/> Std.Dev</td> <td><input type="checkbox"/> C.V.</td> </tr> <tr> <td><input checked="" type="checkbox"/> Total solids concentration</td> <td><input type="checkbox"/> Std.Dev</td> <td><input type="checkbox"/> C.V.</td> </tr> <tr> <td><input checked="" type="checkbox"/> Percent porosity</td> <td><input type="checkbox"/> Std.Dev</td> <td><input type="checkbox"/> C.V.</td> </tr> <tr> <td><input type="checkbox"/> Temperature</td> <td><input type="checkbox"/> Std.Dev</td> <td><input type="checkbox"/> C.V.</td> </tr> <tr> <td colspan="3"> </td> </tr> <tr> <td><input type="checkbox"/> Sample mass</td> <td><input type="checkbox"/> Equilibration rate</td> <td></td> </tr> <tr> <td><input type="checkbox"/> Solids density</td> <td><input type="checkbox"/> Equilibration interval</td> <td></td> </tr> <tr> <td><input type="checkbox"/> Liquids density</td> <td><input type="checkbox"/> Number of purges</td> <td></td> </tr> <tr> <td><input type="checkbox"/> Envelope density</td> <td><input type="checkbox"/> Number of cycles</td> <td></td> </tr> <tr> <td><input type="checkbox"/> Bulk density</td> <td><input type="checkbox"/> Purge fill pressure</td> <td></td> </tr> <tr> <td><input type="checkbox"/> Parameter 1</td> <td><input type="checkbox"/> Cycle fill pressure</td> <td></td> </tr> <tr> <td><input type="checkbox"/> Parameter 2</td> <td><input type="checkbox"/> Cell volume</td> <td></td> </tr> <tr> <td><input type="checkbox"/> Parameter 3</td> <td><input type="checkbox"/> Expansion volume</td> <td></td> </tr> <tr> <td colspan="3" style="text-align: center; margin-top: 10px;"> <input type="button" value="OK"/> <input type="button" value="Cancel"/> </td> </tr> </table> </div>	<input type="checkbox"/> Volume	<input type="checkbox"/> Std.Dev	<input type="checkbox"/> C.V.	<input type="checkbox"/> Density	<input checked="" type="checkbox"/> Std.Dev	<input type="checkbox"/> C.V.	<input checked="" type="checkbox"/> Specific gravity	<input type="checkbox"/> Std.Dev	<input type="checkbox"/> C.V.	<input checked="" type="checkbox"/> Total pore volume	<input type="checkbox"/> Std.Dev	<input type="checkbox"/> C.V.	<input checked="" type="checkbox"/> Total solids concentration	<input type="checkbox"/> Std.Dev	<input type="checkbox"/> C.V.	<input checked="" type="checkbox"/> Percent porosity	<input type="checkbox"/> Std.Dev	<input type="checkbox"/> C.V.	<input type="checkbox"/> Temperature	<input type="checkbox"/> Std.Dev	<input type="checkbox"/> C.V.				<input type="checkbox"/> Sample mass	<input type="checkbox"/> Equilibration rate		<input type="checkbox"/> Solids density	<input type="checkbox"/> Equilibration interval		<input type="checkbox"/> Liquids density	<input type="checkbox"/> Number of purges		<input type="checkbox"/> Envelope density	<input type="checkbox"/> Number of cycles		<input type="checkbox"/> Bulk density	<input type="checkbox"/> Purge fill pressure		<input type="checkbox"/> Parameter 1	<input type="checkbox"/> Cycle fill pressure		<input type="checkbox"/> Parameter 2	<input type="checkbox"/> Cell volume		<input type="checkbox"/> Parameter 3	<input type="checkbox"/> Expansion volume		<input type="button" value="OK"/> <input type="button" value="Cancel"/>		
<input type="checkbox"/> Volume	<input type="checkbox"/> Std.Dev	<input type="checkbox"/> C.V.																																																		
<input type="checkbox"/> Density	<input checked="" type="checkbox"/> Std.Dev	<input type="checkbox"/> C.V.																																																		
<input checked="" type="checkbox"/> Specific gravity	<input type="checkbox"/> Std.Dev	<input type="checkbox"/> C.V.																																																		
<input checked="" type="checkbox"/> Total pore volume	<input type="checkbox"/> Std.Dev	<input type="checkbox"/> C.V.																																																		
<input checked="" type="checkbox"/> Total solids concentration	<input type="checkbox"/> Std.Dev	<input type="checkbox"/> C.V.																																																		
<input checked="" type="checkbox"/> Percent porosity	<input type="checkbox"/> Std.Dev	<input type="checkbox"/> C.V.																																																		
<input type="checkbox"/> Temperature	<input type="checkbox"/> Std.Dev	<input type="checkbox"/> C.V.																																																		
<input type="checkbox"/> Sample mass	<input type="checkbox"/> Equilibration rate																																																			
<input type="checkbox"/> Solids density	<input type="checkbox"/> Equilibration interval																																																			
<input type="checkbox"/> Liquids density	<input type="checkbox"/> Number of purges																																																			
<input type="checkbox"/> Envelope density	<input type="checkbox"/> Number of cycles																																																			
<input type="checkbox"/> Bulk density	<input type="checkbox"/> Purge fill pressure																																																			
<input type="checkbox"/> Parameter 1	<input type="checkbox"/> Cycle fill pressure																																																			
<input type="checkbox"/> Parameter 2	<input type="checkbox"/> Cell volume																																																			
<input type="checkbox"/> Parameter 3	<input type="checkbox"/> Expansion volume																																																			
<input type="button" value="OK"/> <input type="button" value="Cancel"/>																																																				
<b>Recalculate SPC results when reporting</b> [ <i>check box</i> ]	<p>The first time this option is used, the time it takes to generate the report is lengthened. The second time the report is generated, if using the same sample files used in the initial calculation, it is recommended that this option not be selected since the data was recalculated previously. If a sample file is added or removed from the report after the initial recalculation, this option should be selected again to ensure the data from the newly added or removed sample file is recalculated.</p>																																																			

## SPC Report (continued)

Field or Button	Description
<b>Report</b> [button]	Generates the report.
<b>Samples</b> [button]	Select additional sample files to add to the report. Select the samples in the <i>Available Files</i> list box then click <b>Add</b> to move them to the <i>Selected Files</i> list box. Click <b>OK</b> when done.
<b>Selected Reports</b> [group box]	Select the report names to include in the report. Highlight the report name, then click <b>Edit</b> to modify report parameters.
<b>Show graphic</b> [check box]	Use to show a graphic on the report header.  <b>Height/Width.</b> Enter the height and width of the selected graphic. These values determine the graphic appearance on the generated report.
<b>Show report title</b> [text box]	Enter a report title to appear on the report header.
<b>SPC Report options</b> [drop-down box]	Select the applicable Control or Regression report from the list.
 <p>For fields and buttons not listed in this table, see <a href="#">Common Fields and Buttons on page 3 - 2</a>.</p>	

## REPORT FEATURES AND SHORTCUTS

Reports can be customized and manipulated using the toolbar, shortcut menus, the zoom feature, or axis cross-hairs.

- After analysis, reports can be viewed, printed, and/or copied and pasted into other documents.
- The report zoom feature provides the viewing of fine graph details and the ability to shift the axes.
- All reports contain a header displaying file statistics.

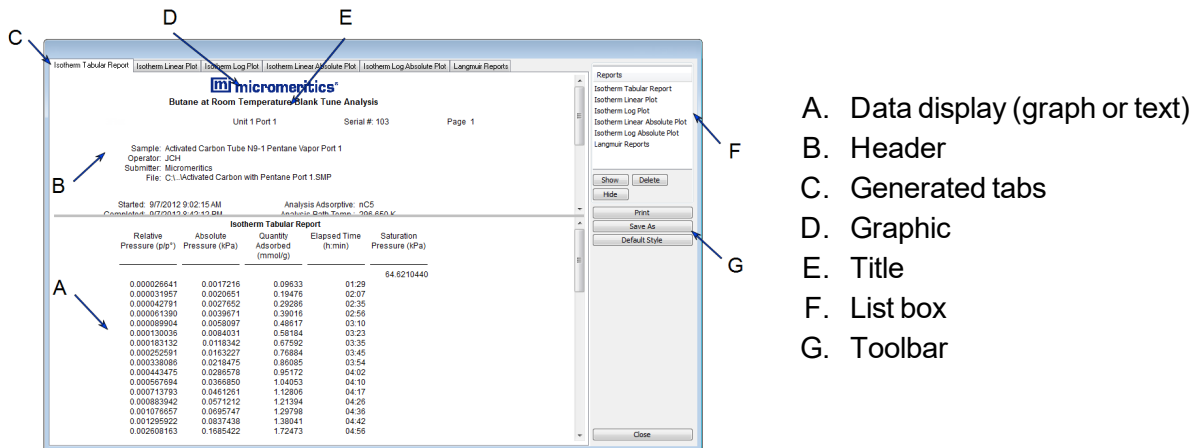

The screenshot shows the 'Isotherm Tabular Report' window. The header includes sample information: 'Sample: Activated Carbon Tube NB-1 Pentane Vapor Port 1', 'Operator: JCH', 'Submitter: Micromeritics', and 'File: C:\Activated Carbon with Pentane Port 1 SMP'. It also shows analysis details: 'Started: 9/7/2012 9:02:15 AM', 'Analysis Adsorptive: nCS', and 'Analysis Bath Temp.: 206.460 V'. The main data table is as follows:

Relative Pressure (pp')	Absolute Pressure (kPa)	Quantity Adsorbed (mmol/g)	Elapsed Time (h:mm)	Saturation Pressure (kPa)
0.000026641	0.0017216	0.09633	01:29	64.8210440
0.000031957	0.0020651	0.19476	02:07	
0.000042791	0.0027552	0.29286	02:35	
0.000061590	0.0039871	0.39015	02:56	
0.000093904	0.0058097	0.48917	03:10	
0.000130039	0.0084031	0.58184	03:23	
0.000183132	0.0116342	0.67592	03:35	
0.000252591	0.0163227	0.76884	03:45	
0.000338086	0.0218475	0.86085	03:54	
0.000443475	0.0296978	0.95172	04:02	
0.000567694	0.0396850	1.04053	04:10	
0.000713793	0.0481261	1.12806	04:17	
0.000883962	0.0571212	1.21394	04:25	
0.001076657	0.0668747	1.29798	04:36	
0.001295922	0.0837438	1.38041	04:42	
0.002808163	0.1685422	1.72473	04:56	

If configured, the report header can also contain a graphic and/or a title.

- Tabular and graphical reports contain sample and analyzer statistics such as analysis date / time, analysis conditions, etc.
- The headers contain notes of sample file changes occurring after analysis.
- Summary report headers contain the same information as tabular and graphical reports with the exception of notes.

## REPORT HEADER SHORTCUTS

Right click in the report header to display header shortcuts.

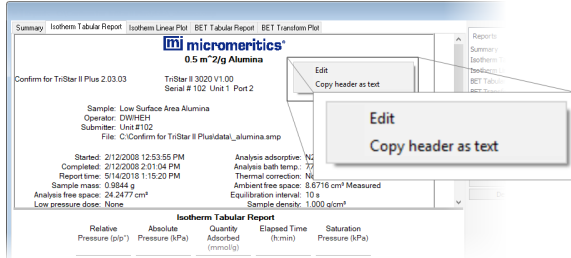

### Report Header Shortcuts

Field or Button	Description
<b>Copy header as text</b>	Use to copy the report header as text. Text is copied to the clipboard and then can be pasted into other documents.
<b>Edit</b>	Use to edit the report title and/or graphic in the report header.

## REPORT TOOLBAR

The *Report* window has a toolbar on the right portion of the window and selectable tabs at the top of the report header. To view a specific report, either select the tab or the report in the *Reports* list box, then click **Show**.

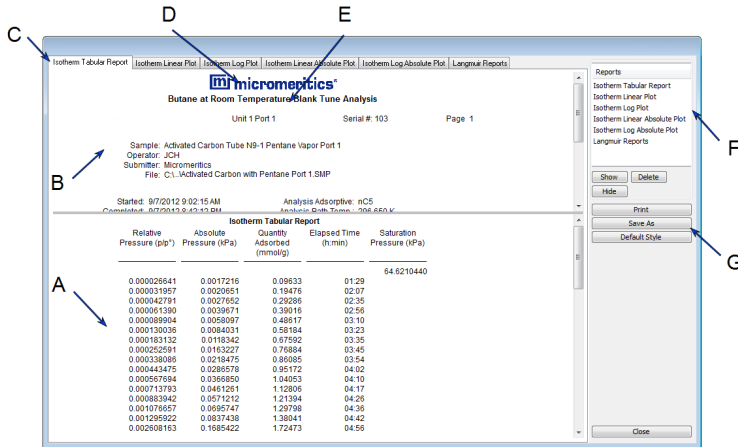

- A. Data display (graph or text)
- B. Header
- C. Generated tabs
- D. Graphic
- E. Title
- F. List box
- G. Toolbar

## Report Toolbar

Field or Button	Description
<b>Default Style</b> [button]	Specify default report parameters for fonts and curve properties.
<b>Delete</b> [button]	Deletes the selected report in the <i>Reports</i> list box. Deleted reports will have to be regenerated if deleted in error.
<b>Hide</b> [button]	Hides (or temporarily removes) the selected report from the tabbed view. The report name remains in the <i>Reports</i> list box.
<b>Print</b> [button]	Displays the <i>Print</i> window for report output.
<b>Reports</b> [group box]	Contains a list of all generated reports. The same reports display as tabs at the top of the report header unless the report has been hidden using the <b>Hide</b> button.
<b>Show</b> [button]	Displays the selected or hidden report in the <i>Reports</i> list box.

**For fields and buttons not listed in this table, see [Common Fields and Buttons on page 3 - 2](#).**

## TABULAR REPORT FEATURES AND SHORTCUTS

Right click in the report header to display tabular report shortcuts.. Right click on a column to display column shortcuts.

Pressure (psia)	Pore Diameter (nm)	Incremental Pore Volume (mL/g)	Cumulative Pore Volume (mL/g)
1.60	113035.46	0.0000	0.0000
2.10	86233.90	0.0003	0.0003
3.08	58736.62	0.0010	0.0013
4.08	44235.22	0.0009	0.0022
5.58	32383.88	0.0012	0.0035
7.08	25548.88	0.0013	0.0048
8.55	21151.04	0.0015	0.0063
10.54	17163.20	0.0028	0.0088
13.04	13871.48	0.0020	0.0140
14.74	12272.43	0.0030	0.0170
16.02	11290.45	0.0021	0.0191
20.01	9039.95	0.0046	0.0237
20.51	8818.71	0.0005	0.0242

### Tabular Reports Shortcut Options

Field or Button	Description
<b>Align column</b>	Select to change the column alignment to either left, right, or centered.
<b>Copy table as text</b>	Use to copy the report contents to the clipboard as tab-delimited text. It can then be pasted into another document.
<b>Edit title</b>	Use to edit the report title and/or title font attributes. Click <b>Font</b> to modify font attributes.
<b>Move column</b>	Right click the column to be moved. Select <i>Move column</i> on the shortcut menu and select <i>Left</i> or <i>Right</i> for the move.
<b>Rename column</b>	Right click the column to be renamed. Select <i>Rename column</i> on the shortcut menu and enter the new column name.
<b>Resize column</b>	Right click the column to be resized. Select <i>Resize column</i> on the shortcut menu and enter the new column width in inches.
<b>Show column</b>	Displays a list of all columns. Click a column to add a checkmark to show the column or remove the checkmark to hide the column.
<b>Table data font</b>	Right click in the report data. Select <i>Table data font</i> on the shortcut menu.
<b>Table header font</b>	Right click in the report data. Select <i>Table header font</i> on the shortcut menu.

**For fields and buttons not listed in this table, see [Common Fields and Buttons on page 3 - 2](#).**

## GRAPH FEATURES AND SHORTCUTS

Display graph report shortcuts by right clicking in the body of the graph report.

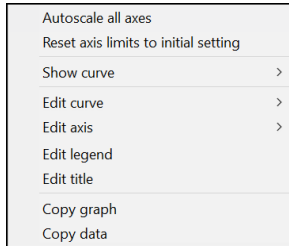

### Graph Shortcuts Options

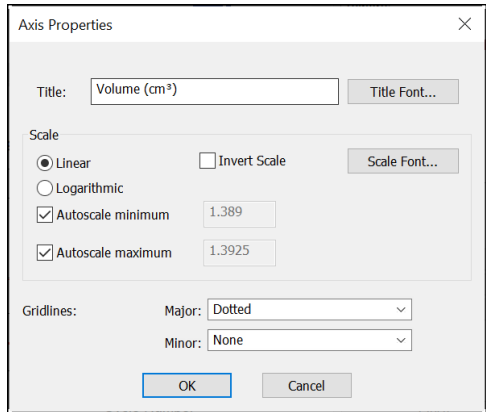

Field or Button	Description
<b>Autoscale all axes</b>	Returns the report to full view after using the zoom feature.
<b>Copy data</b>	Copies the report data to the clipboard. It can then be pasted into other software programs as tab-delimited columns or copied as an overlay onto another graph.
<b>Copy graph</b>	Copies the report graph to the clipboard. It can then be pasted into other software programs or copied as an overlay onto another graph.
<b>Edit axis</b>	Use to edit the selected axis properties. <div data-bbox="553 1035 1036 1444" data-label="Image">  </div> <p><b>Autoscale minimum / maximum.</b> To manually specify minimum / maximum autoscale, deselect the option and enter the new amount in the text box.</p> <p><b>Grid lines.</b> Use to change how to display major / minor grid lines.</p> <p><b>Invert scale.</b> Use to invert the scale.</p> <p><b>Linear / Logarithmic.</b> Select the option to scale the graph as linear or</p>

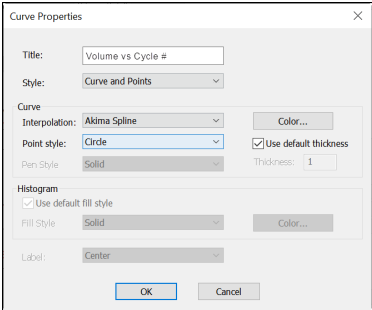

## Graph Shortcuts Options (continued)

Field or Button	Description
	<p>logarithmic.</p> <p><b>Scale font.</b> Use to modify the font for the scale label. Deselect <i>Use default font</i> to enable font options.</p> <p><b>Title.</b> Use to edit the selected axis label.</p> <p><b>Title font.</b> Use to modify the font for the selected axis label. Deselect <i>Use default font</i>. Select new font attributes for report data. Enable <i>Use default font</i> to reset default fonts.</p>
<b>Edit curve</b>	<p>Use to edit selected curve properties.</p>  <p><b>Color.</b> Click to change the curve color.</p> <ul style="list-style-type: none"> <li>■ <b>Curve group box.</b> Use to change the interpolation, point style and pen style for the selected curve. These options are disabled if <i>Use default fill style</i> is selected in the <i>Histogram</i> group box.</li> <li>■ <b>Histogram group box.</b> Enabled only if <i>Histogram</i> is selected in the <i>Style</i> drop-down list. Use to specify the type of fill, fill color and label position for the selected curve.</li> </ul> <p><b>Label.</b> Select where the graph point labels will display (left, right, center, etc.) on the SPC report.</p> <p><b>Style.</b> Use to select another style for the collected data curve.</p> <p><b>Title.</b> Use to change the title of the selected curve.</p> <p><b>Use default thickness.</b> Uses the default curve thickness. Deselect to enter a new thickness number in the <i>Thickness</i> text box.</p>

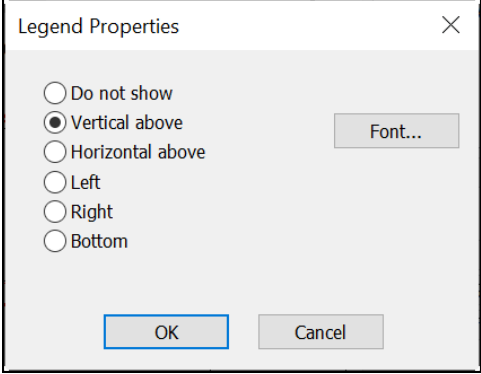
## Graph Shortcuts Options (continued)

Field or Button	Description
<b>Edit legend</b>	Use to change the legend location and font. Click <b>Font</b> to modify font attributes.  
<b>Edit title</b>	Use to change the graph title and font. Click <b>Font</b> to change font attributes.
<b>Reset axis limited to initial setting</b>	Removes the cross-hair and returns the graph back to the initial setting.
<b>Show curve</b>	Displays a list of all curves. Select the curve to display.
	For fields and buttons not listed in this table, see <a href="#">Common Fields and Buttons on page 3 - 2</a> .

## AXIS CROSS-HAIR

Left click on the graph to view the cross-hair coordinates.

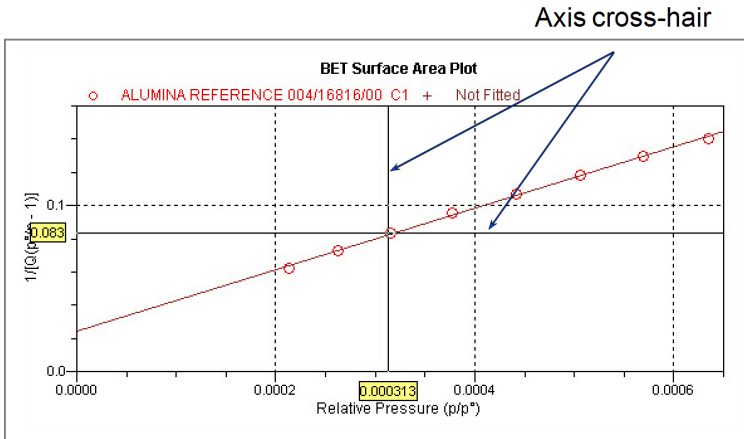

**Example of Axis cross-hair feature**

## GRAPH GRID LINES

### Options > Graph Grid Lines

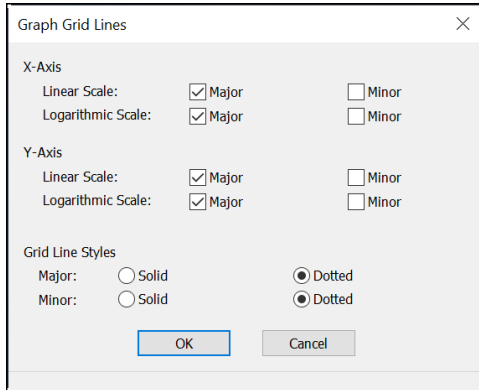

Use to select how grid lines appear on reports. This menu option is not available if using *Restricted* option presentation.

### Graph Grid Lines

Field or Button	Description
<b>Grid Line Styles</b> [selection]	Select if the major and/or minor grid lines should appear as solid or dotted lines.
<b>X-Axis / Y-Axis</b> [selection]	Select major and/or minor lines to display in reports for the logarithmic and linear scales. Deselect this option to remove the grid lines.
 For fields and buttons not listed in this table, see <a href="#">Common Fields and Buttons on page 3 - 2</a> .	

## ZOOM FEATURE

Use the zoom feature to examine graph details. Click, hold, and drag the left mouse button on the graphical area to be enlarged. A box will display in the area to be enlarged. To return to normal view, right click in the graph and select *Autoscale all axes*.

## GRAPH AND SAMPLE OVERLAYS

### CFR Note

In 21CFR11 environments, this feature is applicable to members of the Developer group only.

Use the graph overlay functions to compare multiple graph options. Graphical lines are differentiated by the use of varying colored symbols outlined on a legend. Overlays may be generated in two ways:

- **Multiple Graph Overlays.** Overlay two different types of graphs from one sample.
- **Multiple Sample Overlays.** Overlay graphs of the same type with that of the current plot.



This feature is available only when using *Advanced* option presentation. Go to **Options > Option Presentation > Advanced**.

## GENERATE MULTIPLE GRAPH OVERLAYS

1. Go to **Options > Option Presentation** and ensure there is a checkmark to the left of *Advanced*.
2. Go to **File > Open** and open the sample file.
3. On the *Report Options* tab, in the *Selected Reports* list box, highlight the graph to be used for multiple overlays, then click **Edit**.

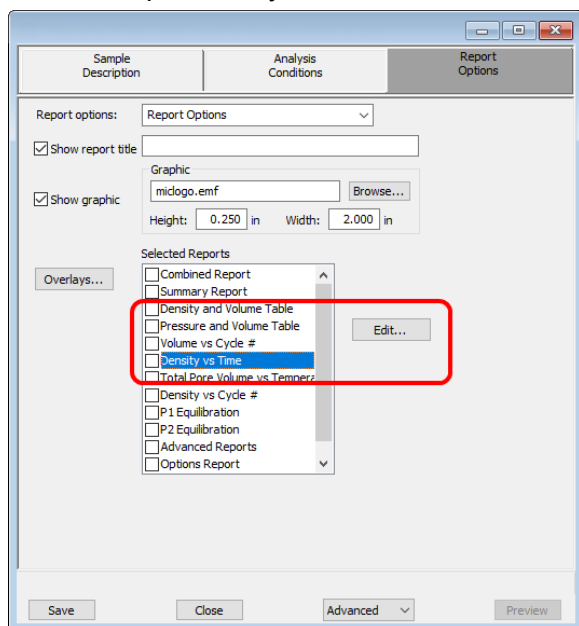

4. On the *Plot Options* window, select a quantity from the overlay list. If the x- and/or y-axes are to be autoscaled, select *Autoscale*; otherwise, enter the *From* and *To* points for the axes.

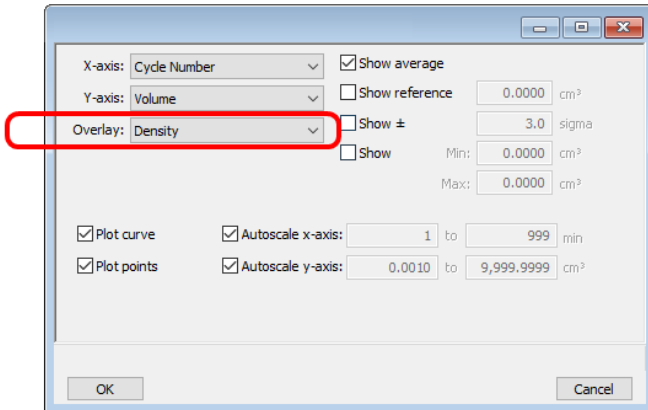

5. Click **OK** then click **Save**.
6. Select the overlay *X-axis*, *Y-axis*, and *Overlay* options.
7. Click **OK** to return to the *Report Options* tab.
8. Click **Save**, **Save As**, or **Preview**.

## GENERATE MULTIPLE SAMPLE OVERLAYS

1. Go to **Options > Option Presentation** and ensure there is a checkmark to the left of **Advanced**.
2. Go to **File > Open** and open the sample file.
3. Click the **Report Options** tab.
4. In the **Selected Reports** list box, select the checkbox to the left of each report to include in the graph overlay.
5. Highlight the graph to be used for multiple overlays, then click **Edit**.

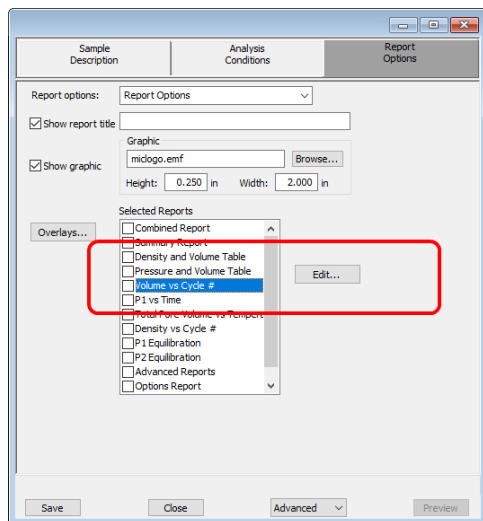

6. On the overlay window, click the down arrow to the right of the **Overlay** field and select **Overlay Samples**. Select other options as needed, then click **OK**.

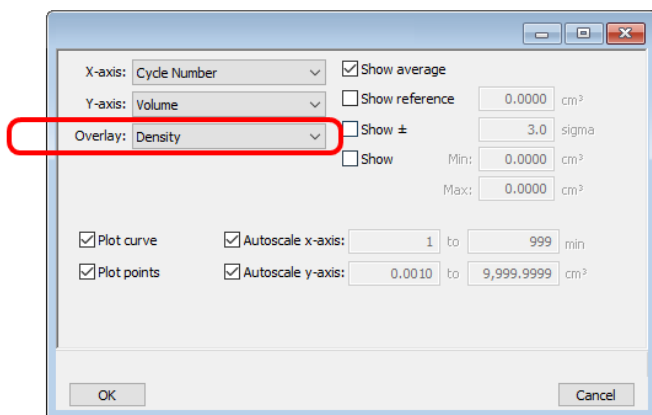

7. In the *Report Options* tab, click **Overlays**.

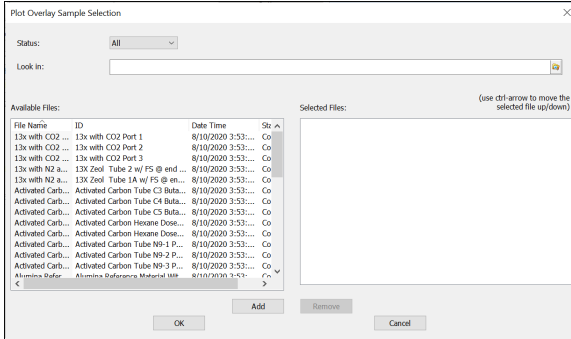

**Example of Overlay window**

8. On the *Overlays* window, move up to 25 files from the *Available Files* box to the *Selected Files* box. If the files to be overlaid do not display in the *Available Files* list, click the *Browse* icon to locate and select which graphs are to be overlaid.
9. Click **OK**.
10. Go to **Reports > Start Report**. Select the report destination in the *Settings* group box. Select the overlay file name in the *Files* list box, then click **OK**.
11. In the pop-up *Selected Reports* list box, reports can be added or removed by double clicking the entry. Selected reports are indicated by a checkmark to the left. Click **OK**.
12. Reports display in a tabbed format. Click each tab to view each report.

### Overlay Sample Selection

Field	Description
<b>Status</b> [drop-down box]	Select the status of files to be combined.
<b>Look in</b> [button]	Click the <b>Browse</b> icon to change the file folder location.
<b>Available Files</b> [selection]	Lists files that meet the selected criteria. Select the files to be combined, then click <b>Add</b> . The selected files are moved to the <i>Selected Files</i> list box.
<b>Selected Files</b> [selection]	Lists the files selected to be combined. Click <b>OK</b> to combine the files.



For fields and buttons not listed in this table, see [Common Fields and Buttons on page 3 - 2](#).



## REPORT EXAMPLES FOR PYCNOMETRY ANALYZERS

### COMBINED REPORT



4356 Communications Drive Norcross, GA 30093

AccuPyc II 1340 Asphalt V2.00                      Unit 1                      Serial #: 2366                      Page 1

Sample: S/N 2366 1cc Volume Check  
 Operator: AL  
 Submitter: MAS  
 Bar Code: Sphere Volume = 0.717913 - 0.719141  
 File: C:\DATA\1406472C.SMP

Analysis Gas: Nitrogen                      Analysis Start: 9/2/2014 7:54:30AM  
 Reported: 10/7/2014 1:36:57PM                      Analysis End: 9/2/2014 8:34:14AM  
 Sample Mass: 1.0000 g                      Equilib. Rate: 0.005 psig/min  
 Temperature: 23.22 °C                      Expansion Volume: 0.8697 cm<sup>3</sup>  
 Number of Purges: 10                      Cell Volume: 1.3300 cm<sup>3</sup>  
 Chamber Insert: None

Comments: Total number of pages: 1

Combined Report  
 Summary Report  
 Sample Volume  
 Average: 0.7189 cm<sup>3</sup>  
 Standard Deviation: 0.0000 cm<sup>3</sup>  
 Sample Density  
 Average: 1.3910 g/cm<sup>3</sup>  
 Standard Deviation: 0.0001 g/cm<sup>3</sup>

Tabular 1					
Cycle#	P1 Pressure (psig)	P2 Pressure (psig)	Volume (cm <sup>3</sup> )	Density (g/cm <sup>3</sup> )	Total Pore Volume (cm <sup>3</sup> /g)
1	19.5155	11.4624	0.7190	1.3909	0.2810
2	19.5252	11.4678	0.7189	1.3909	0.2811
3	19.5222	11.4658	0.7189	1.3910	0.2811
4	19.5291	11.4696	0.7189	1.3911	0.2811
5	19.5164	11.4622	0.7189	1.3911	0.2811
6	19.5199	11.4644	0.7189	1.3910	0.2811
7	19.5279	11.4685	0.7188	1.3912	0.2812
8	19.5274	11.4685	0.7189	1.3911	0.2811
9	19.5154	11.4612	0.7188	1.3911	0.2812
10	19.5275	11.4687	0.7189	1.3911	0.2811

Summary Data	Average	Standard Deviation
Volume:	0.7189 cm <sup>3</sup>	0.0000 cm <sup>3</sup>
Density:	1.3910 g/cm <sup>3</sup>	0.0001 g/cm <sup>3</sup>

6202- Total solids concentration is invalid; liquid density is greater than or equal to solids density.

**SUMMARY REPORT**

  
4356 Communication Drive Norcross, GA 30093

AccuPyc II 1340 FoamPyc V2.00                      Unit 3                      Serial #: 108                      Page 1

Sample: Glass Powder  
Operator: HH  
Submitter: Micromeritics  
Bar Code:  
File: C:\DATA\GLASS.SMP

Analysis Gas: Helium Reported: 11/26/2014 10:35:20AM Sample Mass: 5.9637 g Temperature: 23.79 °C Number of Purges: 10 Chamber Insert: None	Analysis Start: 1/22/2007 2:40:48PM Analysis End: 1/22/2007 3:12:00PM Equilib. Rate: 0.005 psig/min Expansion Volume: 9.1029 cm <sup>3</sup> Cell Volume: 11.2990 cm <sup>3</sup>
---	---

Comments: Sample 1

**Summary Report**  
Sample Volume  
Average: 2.2428 cm<sup>3</sup>  
Standard Deviation: 0.0015 cm<sup>3</sup>  
  
Sample Density  
Average: 2.6591 g/cm<sup>3</sup>  
Standard Deviation: 0.0018 g/cm<sup>3</sup>

**TABULAR REPORT**

 4356 Communication Drive Norcross, GA 30093						
AccuPyc II 1340 FoamPyc V2.00	Unit 3	Serial #: 108	Page 2			
Sample: Glass Powder Operator: HH Submitter: Micromeritics Bar Code: File: C:\DATA\GLASS.SMP						
Analysis Gas: Helium Reported: 11/26/2014 10:35:20AM Sample Mass: 5.9637 g Temperature: 23.79 °C Number of Purges: 10 Chamber Insert: None			Analysis Start: 1/22/2007 2:40:48PM Analysis End: 1/22/2007 3:12:00PM Equilib. Rate: 0.005 psig/min Expansion Volume: 9.1029 cm <sup>3</sup> Cell Volume: 11.2990 cm <sup>3</sup>			
Comments: Sample 1						
Density and Volume Report						
Cycle#	Volume (cm <sup>3</sup> )	P2 Pressure Deviation (psig)	Density (g/cm <sup>3</sup> )	Volume Deviation (cm <sup>3</sup> )	Temperature (°C)	Porosity* (%)
1	2.2418	-0.017	2.6602	-0.0010	23.72	62.41
2	2.2446	-0.006	2.6589	0.0018	23.74	62.36
3	2.2410	-0.028	2.6612	-0.0018	23.75	62.42
4	2.2408	-0.014	2.6614	-0.0019	23.77	62.43
5	2.2423	-0.012	2.6596	-0.0005	23.78	62.40
6	2.2437	0.002	2.6580	0.0009	23.80	62.38
7	2.2434	0.032	2.6584	0.0006	23.83	62.38
8	2.2457	0.027	2.6557	0.0029	23.83	62.34
9	2.2417	0.013	2.6603	-0.0011	23.85	62.41
10	2.2428	0.004	2.6590	0.0001	23.87	62.39
Summary Data			Average	Standard Deviation		
Volume:			2.2428 cm <sup>3</sup>	0.0015 cm <sup>3</sup>		
Density:			2.6591 g/cm <sup>3</sup>	0.0018 g/cm <sup>3</sup>		
*Calculated from envelope density						

**GRAPH REPORT**

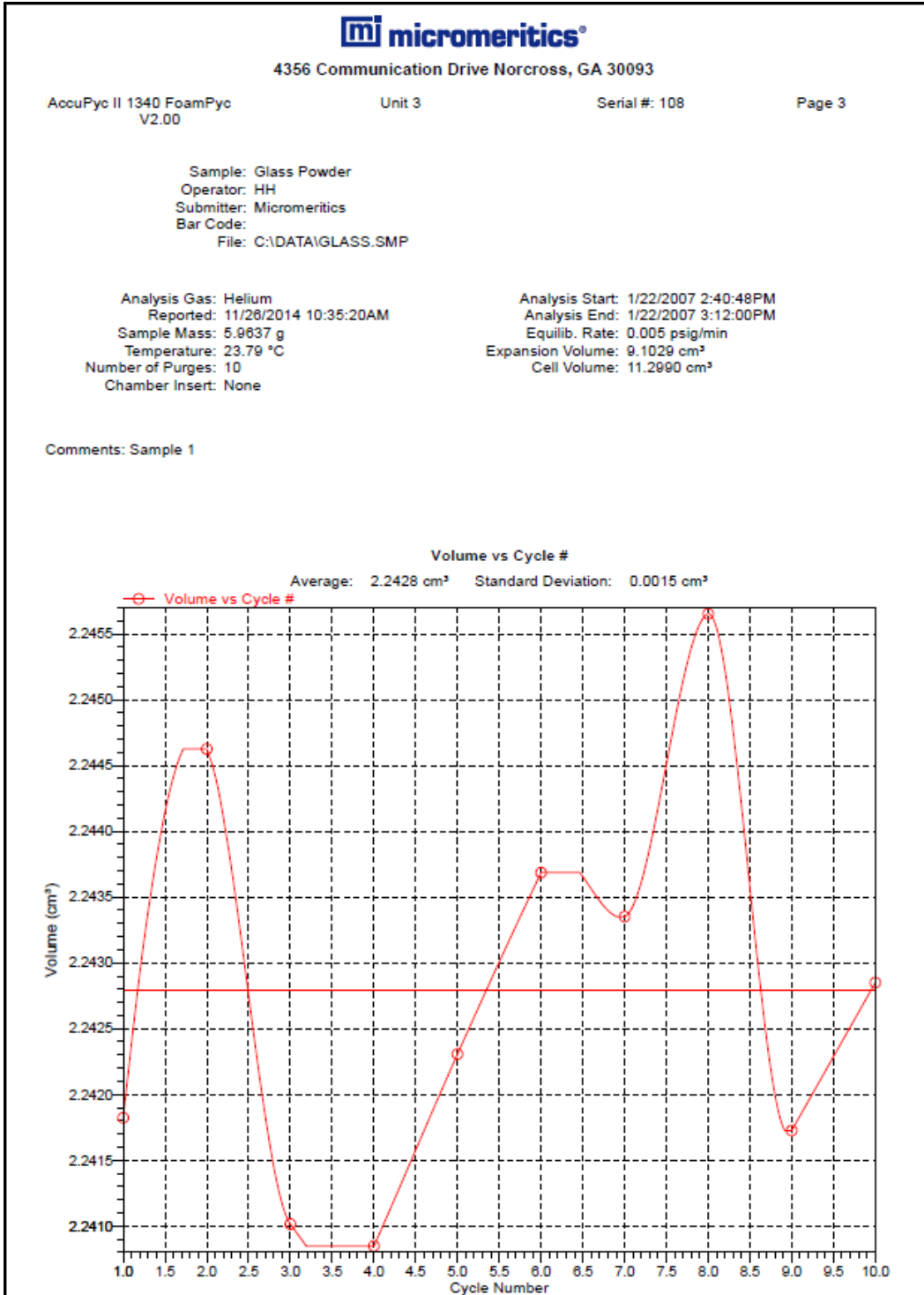

**OVERLAY REPORT**

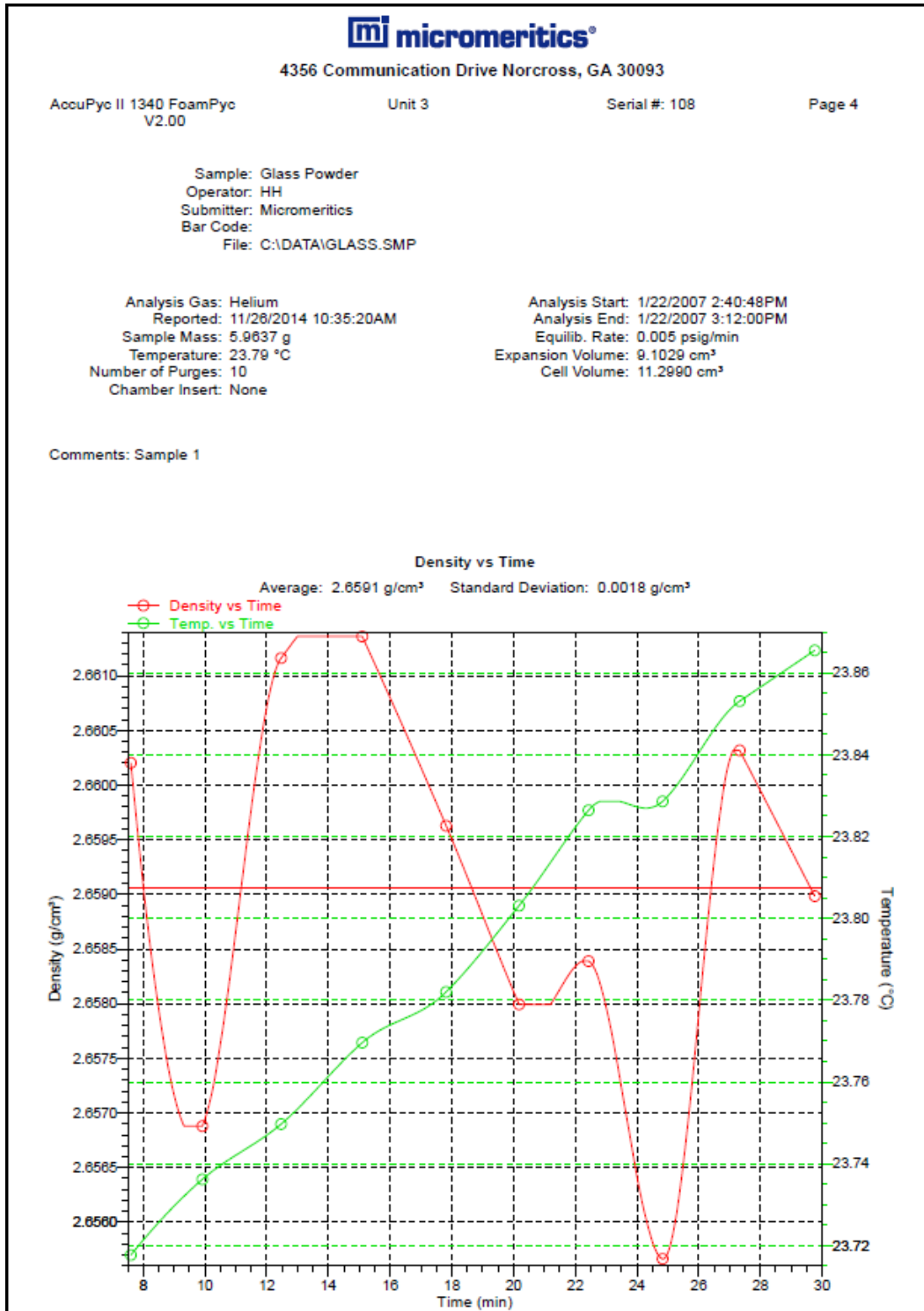

## EQUILIBRATION REPORT

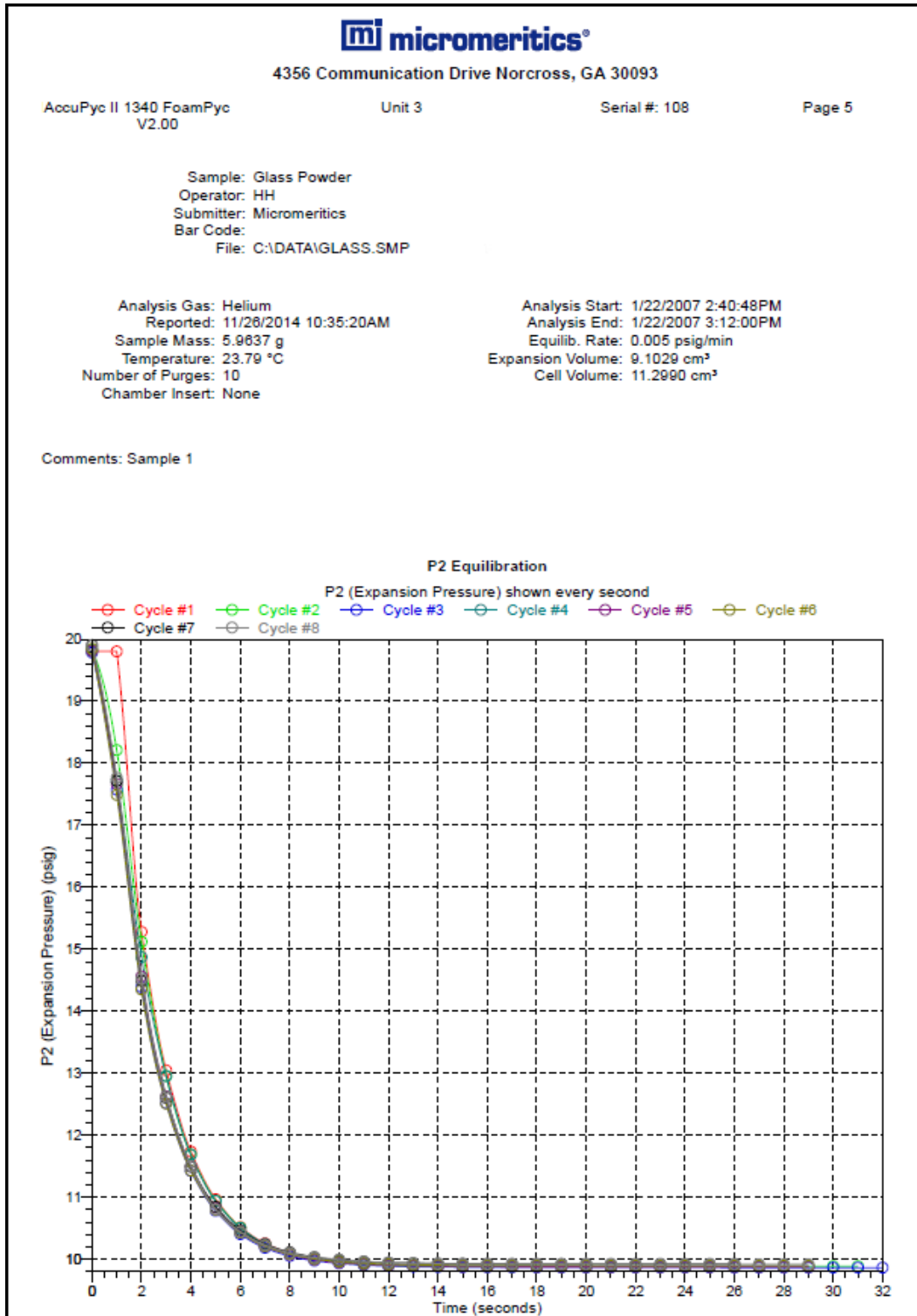

**SAMPLE LOG REPORT**

  
4356 Communications Drive Norcross, GA 30093

AccuPyc II 1340 Asphalt V2.00                      Unit 1                      Serial #: 2366                      Page 1

Sample: S/N 2366 1cc Volume Check  
Operator: AL  
Submitter: MAS  
Bar Code: Sphere Volume = 0.717913 - 0.719141  
File: C:\DATA\1406472C.SMP

Analysis Gas: Nitrogen	Analysis Start: 9/2/2014 7:54:30AM
Reported: 10/7/2014 1:36:57PM	Analysis End: 9/2/2014 8:34:14AM
Sample Mass: 1.0000 g	Equilib. Rate: 0.005 psig/min
Temperature: 23.22 °C	Expansion Volume: 0.8697 cm <sup>3</sup>
Number of Purges: 10	Cell Volume: 1.3300 cm <sup>3</sup>
Chamber Insert: None	

Comments: Total number of pages: 1

Sample log		
Date	Time	Log Message
9/2/2014	7:54:30AM	Analysis started.
9/2/2014	8:34:14AM	Analysis done.

**Blank Page**

---



## 8 SELECTED REPORTS

---

### COMBINED REPORT

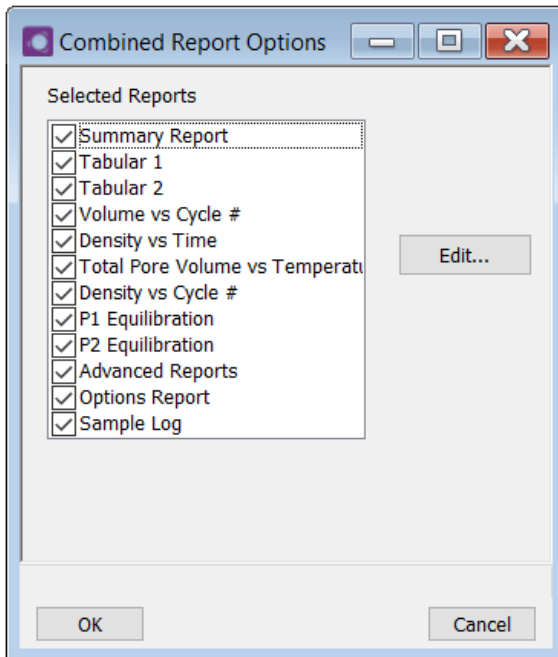

The *Combined Reports* option creates a single report from all selected reports. The *Combined Report* contains no breaks between reports and no headings. Highlight the report, then click [Edit](#) to edit report details.

## DENSITY AND VOLUME TABLE

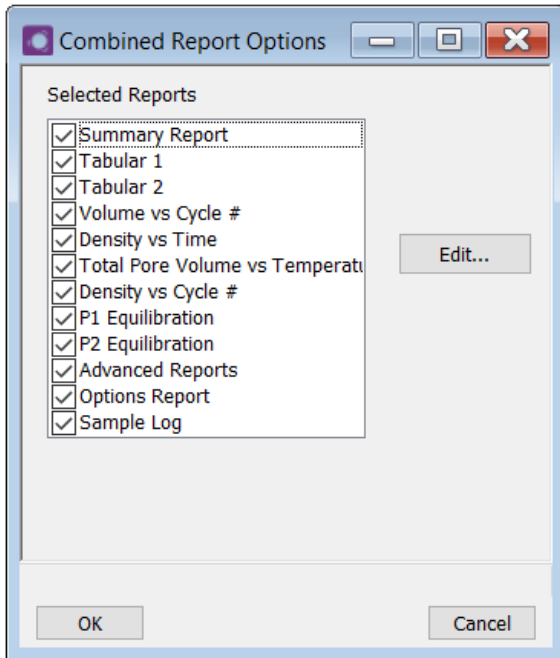

### Density and Volume

Field or Button	Description
<b>Columns 1 through 7</b> [drop-down box]	Select a variable for each column.
<b>Name</b> [text box]	Enter the name of the report.
<b>Summary Data</b> [group box]	Select the average, standard deviation, and coefficient of variation (C.V.) for report parameters.
	For fields and buttons not listed in this table, see <a href="#">Common Fields and Buttons on page 3 - 2</a> .

## DENSITY VOLUME VS CYCLE NUMBER TREND PLOT

There are four types of graphical reports available. Report titles are based on the parameters selected for the x-axis and y-axis.

### Density Volume vs Cycle Number Trend Plot

Field or Button	Description
<b>Autoscale x-axis</b> <b>Autoscale y-axis</b> [check box]	When enabled on the report parameters windows, allows the x- and y- axes to be scaled automatically. <i>Autoscale</i> means that the x- and y- ranges will be set so that all the data is shown. If Autoscale is not selected, the entered range is used.
<b>Overlay</b> [drop-down box]	Select overlay plot options. <ul style="list-style-type: none"> <li>■ A second y-axis can be selected to overlay with the variable in the y-Axis field, or</li> <li>■ Select <i>Overlay Samples</i> to overlay data of the type selected in the y-axis field with the same type of data contained in other sample files. To select other sample files, go to the <i>Report Options</i> tab and click the <b>Overlays</b> button.</li> </ul>
<b>Plot curve</b> <b>Plot points</b> [check box]	Select to display how data are plotted.

## Density Volume vs Cycle Number Trend Plot (continued)

Field or Button	Description
<b>Show +/-</b> [check box]	Select to place two horizontal lines on the graph. The top line will be placed at a point relative to the average and standard deviation of the data. The bottom line will be placed at the point entered in the adjacent field.
<b>Show Average</b> [check box]	Select to show the average of all cycles. A horizontal line is placed at the average point for the cycles.
<b>Show Min</b> <b>Show Max</b> [check box]	Horizontal lines are placed at the entered limits.
<b>Show Reference</b> [check box]	Select to show a horizontal line placed at a reference point specified in the adjacent field.
<b>X-Axis</b> [check box]	Variables available for the x-axis.
<b>Y-Axis</b> [check box]	Variables available for the y-axis.
 <p>For fields and buttons not listed in this table, see <a href="#">Common Fields and Buttons on page 3 - 2</a>.</p>	

## DENSITY VS TIME TREND PLOT

- [Density Volume vs Cycle Number Trend Plot on page 8 - 3](#)

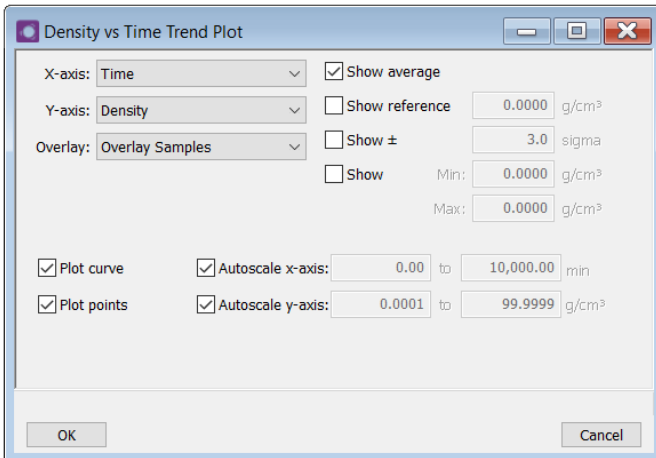

The Density vs Cycle Number Trend Plot and the *Volume vs Cycle Number Trend Plot* are identical except for the x-axis units.

## EQUILIBRATION REPORT

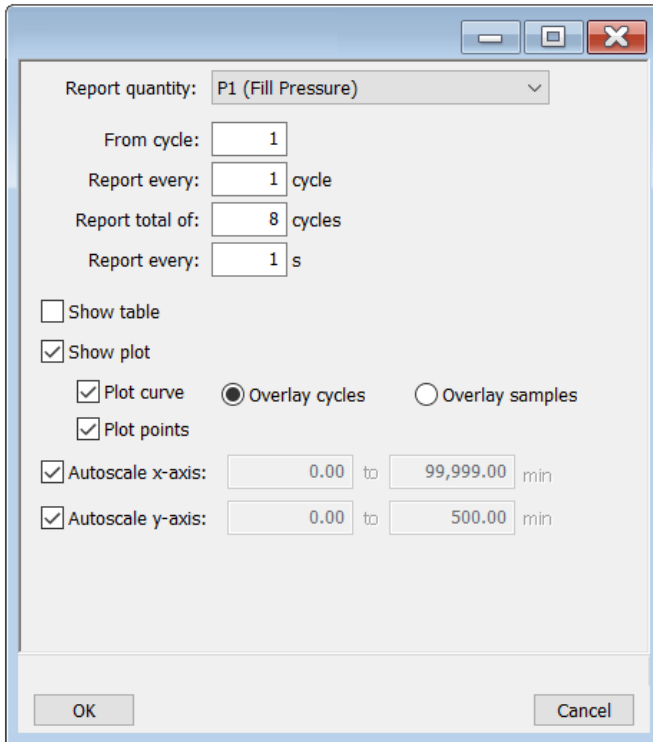

This report is available only if the *Record equilibration data* option was selected on the *Analysis Conditions* tab.

### Equilibration Report

Field or Button	Description
<b>Autoscale x-axis</b> <b>Autoscale y-axis</b> [checkbox]	When enabled on the report parameters windows, allows the x- and y- axes to be scaled automatically. <i>Autoscale</i> means that the x- and y- ranges will be set so that all the data is shown. If Autoscale is not selected, the entered range is used.
<b>From cycle</b> [text box]	Enter the first cycle to report.
<b>Report every</b> [text box]	Enter the interval between reported cycles.
<b>Overlay cycles</b> [checkbox]	Select to overlay the number of cycles entered in the <i>Report total of</i> field.
<b>Overlay samples</b> [checkbox]	Select to overlay the last cycle in the current file with the last cycle contained in other files. Click <b>Overlays</b> on the <i>Report Options</i> tab to select the other sample files.

## Equilibration Report (continued)

Field or Button	Description
<b>Plot curve</b> <b>Plot points</b> [check box]	Select to display how data are plotted.
<b>Report quantity</b> [drop-down box]	Select a variable to be reported.
<b>Report total of</b> [text box]	Enter the number of cycles for this report. Enter up to 8 cycles.
<b>Report every</b> [text box]	Enter time between points. Up to 60 seconds can be entered.
<b>Show plot</b> [check box]	Generates a plot (graph) for the <i>Report quantity</i> field selection.
<b>Show table</b> [check box]	Generates a tabular report for the <i>Report quantity</i> field selection.
	For fields and buttons not listed in this table, see <a href="#">Common Fields and Buttons on page 3 - 2</a> .

## OPTIONS REPORT

The *Options* report provides information on the sample, its material properties, and analysis conditions. This report cannot be edited.

## PRESSURE AND VOLUME TABLE

- [Density and Volume Table on page 8 - 2](#)

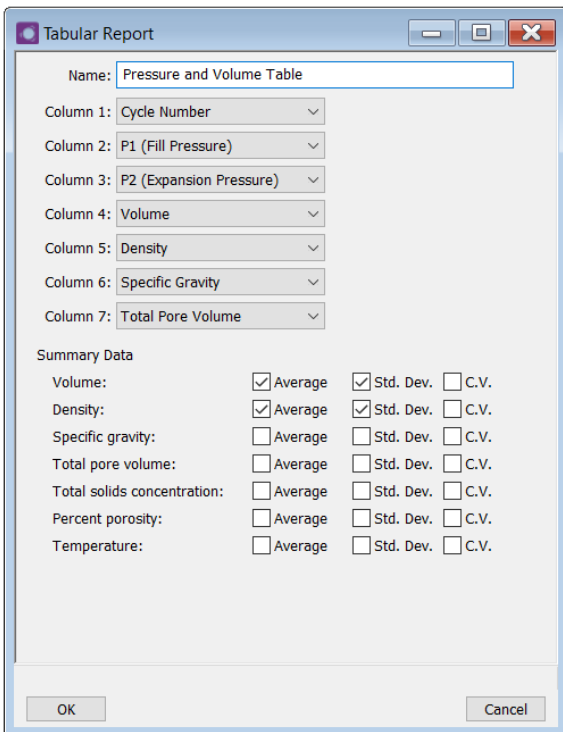

Tabular Report

Name: Pressure and Volume Table

Column 1: Cycle Number

Column 2: P1 (Fill Pressure)

Column 3: P2 (Expansion Pressure)

Column 4: Volume

Column 5: Density

Column 6: Specific Gravity

Column 7: Total Pore Volume

Summary Data

Volume:  Average  Std. Dev.  C.V.

Density:  Average  Std. Dev.  C.V.

Specific gravity:  Average  Std. Dev.  C.V.

Total pore volume:  Average  Std. Dev.  C.V.

Total solids concentration:  Average  Std. Dev.  C.V.

Percent porosity:  Average  Std. Dev.  C.V.

Temperature:  Average  Std. Dev.  C.V.

OK Cancel

The *Pressure and Volume Table* and the *Density and Volume Table* are identical unless otherwise noted.



## SAMPLE LOG REPORT

The Sample Log report displays:

- Automatic operations
- Information entered using **Add Log Entry** on the *Sample Description* tab
- Warnings and/or errors which occurred during analysis

The *Sample Log Report* cannot be edited.

## SUMMARY REPORT

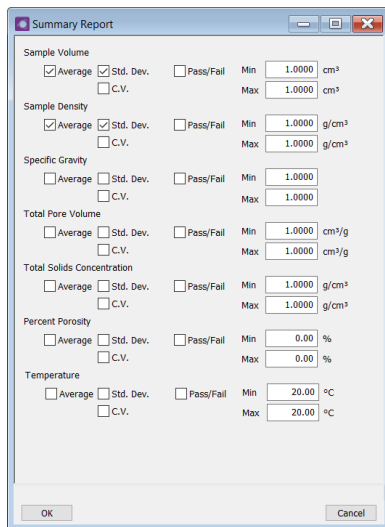

Parameter	Average	Std. Dev.	C.V.	Pass/Fail	Min	Max	Units
Sample Volume	<input checked="" type="checkbox"/>	<input checked="" type="checkbox"/>	<input type="checkbox"/>	<input type="checkbox"/>	1.0000	1.0000	cm <sup>3</sup>
Sample Density	<input checked="" type="checkbox"/>	<input checked="" type="checkbox"/>	<input type="checkbox"/>	<input type="checkbox"/>	1.0000	1.0000	g/cm <sup>3</sup>
Specific Gravity	<input type="checkbox"/>	<input type="checkbox"/>	<input type="checkbox"/>	<input type="checkbox"/>	1.0000	1.0000	
Total Pore Volume	<input type="checkbox"/>	<input type="checkbox"/>	<input type="checkbox"/>	<input type="checkbox"/>	1.0000	1.0000	cm <sup>3</sup> /g
Total Solids Concentration	<input type="checkbox"/>	<input type="checkbox"/>	<input type="checkbox"/>	<input type="checkbox"/>	1.0000	1.0000	g/cm <sup>3</sup>
Percent Porosity	<input type="checkbox"/>	<input type="checkbox"/>	<input type="checkbox"/>	<input type="checkbox"/>	0.00	0.00	%
Temperature	<input type="checkbox"/>	<input type="checkbox"/>	<input type="checkbox"/>	<input type="checkbox"/>	20.00	20.00	°C

**Example of Summary report**

The *Summary Report* provides a condensed listing of data results. Select the type of information to include in the report. If *Pass/Fail* is selected, the *Min* and *Max* fields are enabled. Enter the minimum and maximum values for the pass / fail.

## TOTAL PORE VOLUME VS TEMPERATURE

- [Density Volume vs Cycle Number Trend Plot on page 8 - 3](#)

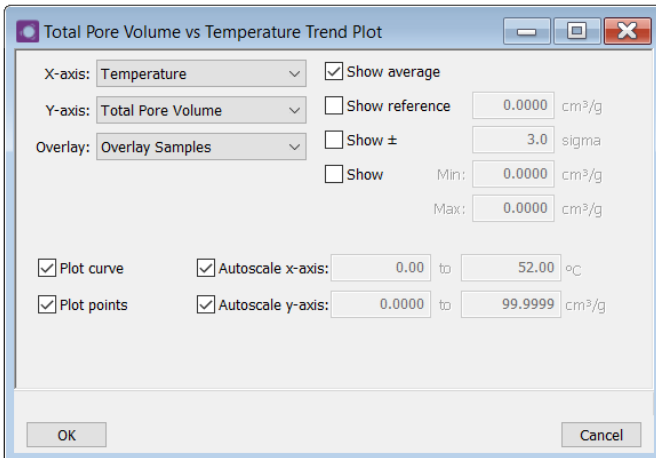

The *Total Pore Volume vs Temperature* and the *Density vs Cycle Number Trend Plot* are identical unless otherwise noted.

## VOLUME VS CYCLE NUMBER TREND PLOT

- [Density Volume vs Cycle Number Trend Plot on page 8 - 3](#)

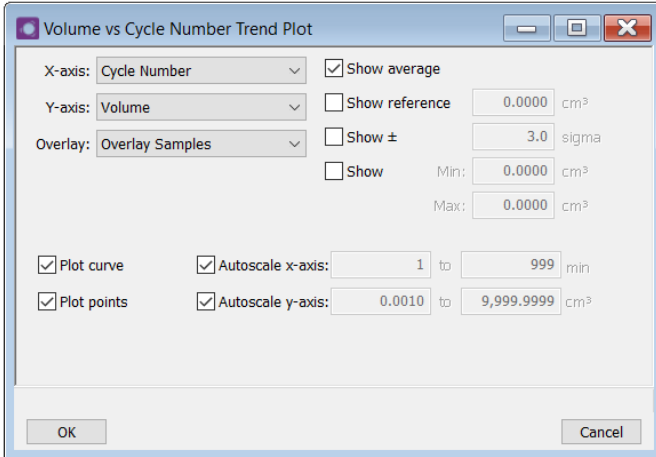

The *Volume vs Cycle Number* and the *Density vs Cycle Number Trend Plot* are identical unless otherwise noted.

**Blank Page**

---

## 9 DIAGNOSTICS USING THE SOFTWARE

### Unit [n] > Diagnostics

Performs a leak test for the analysis module.

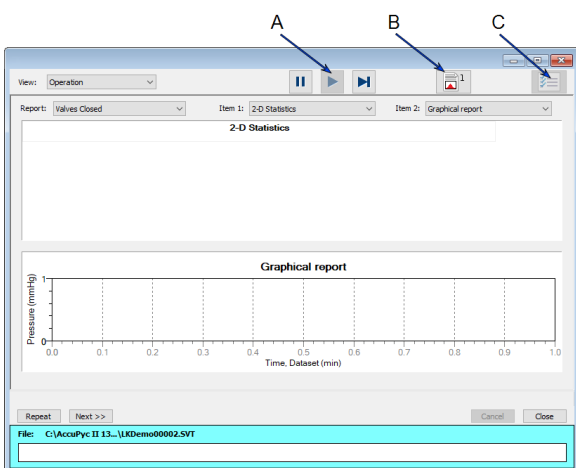
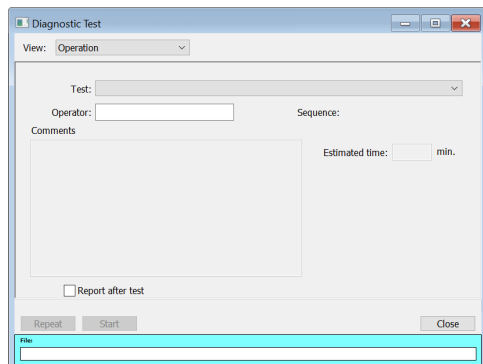

- A. Suspend/Resume/Skip buttons
- B. Port report buttons
- C. Live graph settings

### Diagnostic Test

Field or Button	Description
<b>Estimated time</b>	Amount of time it takes to run the test.
<b>File</b>	Shows a status bar of steps complete once the test begins.
<b>Live Graph</b>	Select graph settings.
<b>Next [button]</b>	Starts the next test.
<b>Operator [text box]</b>	Name of the operator performing the diagnostic.
<b>Repeat [button]</b>	Repeats the test.

## Diagnostic Test (continued)

Field or Button	Description
<b>Report</b>	Generates a report on data being collected . The reports are displayed on the computer monitor only.
<b>Report after test</b> [ <i>check box</i> ]	Automatically generates reports to the selected destination when the test is complete.
<b>Resume</b> [ <i>button</i> ]	Restarts the suspended analysis.
<b>Sequence</b>	Sequence number assigned to the test.
<b>Skip</b> [ <i>button</i> ]	Moves to the next step. This button is visible only when an analysis is in progress. Select the ports to skip. In 21CFR11 environments, steps cannot be skipped.
<b>Start</b> [ <i>button</i> ]	Starts the test.
<b>Status window</b>	Displays the status of the report.
<b>Suspend</b> [ <i>button</i> ]	Suspends an analysis in progress.
<b>Test</b> [ <i>drop-down box</i> ]	Select the appropriate test from the drop-down list.
 <p>For fields and buttons not listed in this table, see <a href="#">Common Fields and Buttons on page 3 - 2</a>.</p>	

## 10 ABOUT CALIBRATION

---

- [Calibrate Using the Keypad on page 10 - 14](#)
- [Calibrate Using the Software below](#)

The pycnometer volume should be calibrated every time it is restarted. Cell volume and expansion volume in the set up parameters are updated automatically upon calibration. Run an analysis with an empty cup to see how close the average volume is to 0. It should be  $\pm 0.05\%$  of full scale. If it is not within  $\pm 0.05\%$  of full scale, calibration is required.

### CALIBRATE USING THE SOFTWARE

If calibrating using the keypad, see [Calibrate Using the Keypad on page 10 - 14](#).

#### CALIBRATE PRESSURE SCALE

**Unit [n] > Calibration > Pressure Scale**

Opens the *Calibrate Pressure Scale* box.

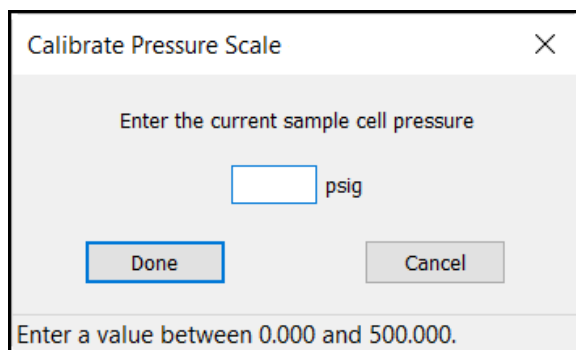

Calibrates the pressure scale. Use an external reference device to determine the sample cell pressure. Enter the value in the field, then click **Done**.

A Calibration report is not generated for the pressure scale. The entry is recorded in the *Instrument Log*. To view the log, go to **Unit [n] > Show Instrument Log**.

1. Enter the current sample cell pressure.
2. Click **Done**. The pressure reading will be adjusted to the entered pressure.

## CALIBRATION REPORT

### Unit [n] > Calibration > Calibration Report

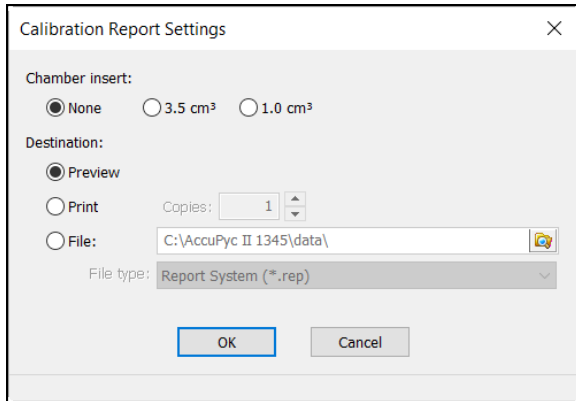

1. Select the type of chamber insert used.
2. Select the report destination.
3. Click **OK** to generate the report.

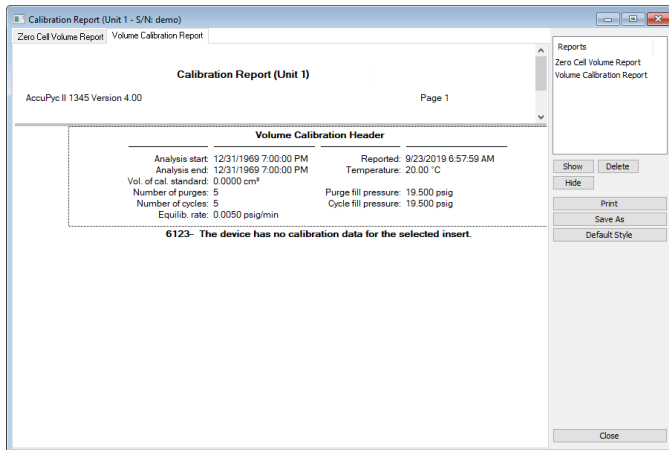



## ***CALIBRATE TEMPERATURE OFFSET***

### ***Unit [n] > Calibration > Temperature***

Opens the *Calibrate Temperature Offset* box.

Calibrates the temperature offset. Use an external reference device to determine the sample cell temperature. Enter the value in the field, then click **Done**.

A Calibration report is not generated for the temperature offset. The entry is recorded in the *Instrument Log*. To view the log, go to **Unit [n] > Show Instrument Log**.

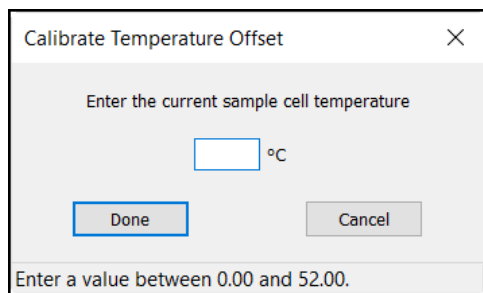

1. Enter the current sample cell temperature.
2. Click **Done**. Temperature reading will be adjusted to the entered temperature.

## CALIBRATE ZERO CELL VOLUME

### Unit [n] > Calibration > Zero Cell Volume

Use to calibrate the cell volume offset.

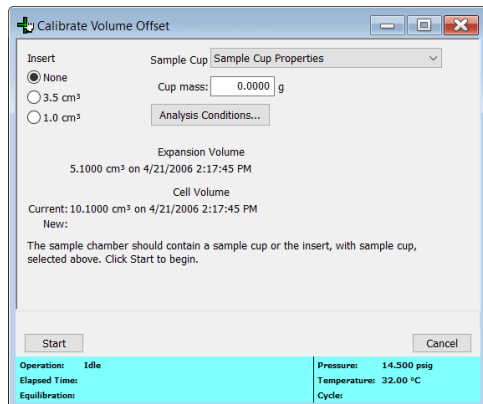

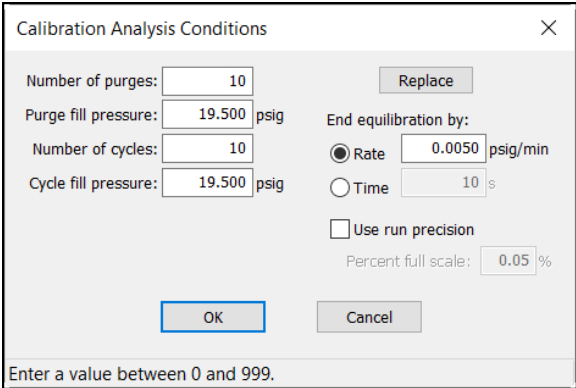
Field or Button	Description
<b>Analysis Conditions</b>	<p>Specify conditions for the calibration.</p>  <p>Click <b>Replace</b> to replace the values with those from an existing <i>Analysis Conditions</i> file. See <a href="#">Analysis Conditions on page 5 - 2</a>.</p>
<b>Cell Volume</b>	Current cell volume (without an insert) or the volume of the selected insert.
<b>Expansion Volume</b>	Current expansion volume, and the date and time of calibration.
<b>Insert</b> <b>1 cm<sup>3</sup> unit</b>	<ul style="list-style-type: none"> <li>■ None</li> <li>■ 0.1 cm<sup>3</sup></li> </ul> <p>If <i>None</i> is selected, place an empty sample cup in the chamber.</p>

Field or Button	Description
Insert 10 cm <sup>3</sup> unit	<ul style="list-style-type: none"> <li>■ None</li> <li>■ 3.5 cm<sup>3</sup></li> </ul> If <i>None</i> is selected, place an empty sample cup in the chamber.
Insert 1.0 cm <sup>3</sup> and 100 cm <sup>3</sup> unit	<ul style="list-style-type: none"> <li>■ None</li> <li>■ 35 cm<sup>3</sup></li> <li>■ 10 cm<sup>3</sup></li> </ul> If <i>None</i> is selected, place an empty sample cup in the chamber.
Insert 350 cm <sup>3</sup> and 2000 cm <sup>3</sup> units	<ul style="list-style-type: none"> <li>■ None</li> <li>■ Large</li> <li>■ Small</li> </ul> If <i>None</i> is selected, place an empty sample cup in the chamber.
 For fields and buttons not listed in this table, see <a href="#">Common Fields and Buttons on page 3 - 2</a> .	

## CALIBRATE ZERO PRESSURE

### Unit [n] > Calibration > Zero Pressure

This option zeros the pressure transducer reading.

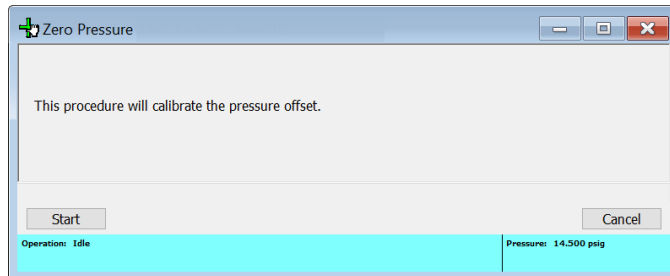

Click **Start** to calibrate the pressure offset.

## **RESET PRESSURE CALIBRATION**

### **Unit [n] > Calibration > Reset Pressure Calibration**

This procedure resets the pressure calibration to the factory default settings.

This option can be used when the pressure appears not to be reported correctly by the analyzer. For example: a zero, negative, or unreasonably high reading is being consistently reported. Resetting to nominal may restore normal pressure readings but a proper calibration should be performed.

A popup warning indicates that when this option is used, the previous pressure calibration is lost and the nominal calibration is used.

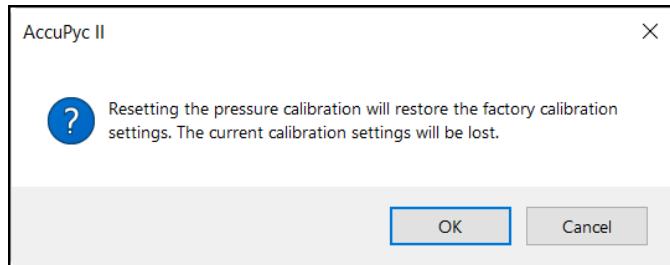

Temperature and volume calibrations are not affected by a reset of the pressure calibration.

Click **OK**. The nominal calibrations may be sufficient. However, it is recommended to contact your Micromeritics Service Representative and schedule a proper pressure calibration as soon as possible since data accuracy may be compromised.

## CALIBRATE VOLUME SCALE

### Unit [n] > Calibration > Calibrate Volume

- [Regulator Pressure on page 12 - 15](#)

Calibrates the cell volume offset and expansion volume.

Although the instrument is calibrated prior to shipment, the pycnometer should be recalibrated to laboratory atmospheric and environmental conditions.

1. Remove the chamber cap and place an empty cup into the sample chamber, then replace the cap. If an insert is being used, place the insert and its sample cup into the chamber.



Wear latex or nitrile, powder-free gloves to prevent transfer of oil from hands when handling sample cups, calibration standards, and inserts. See [Handling System Components on page 11 - 5](#).

2. Go to **Unit [n] > Calibration > Calibrate Volume**.

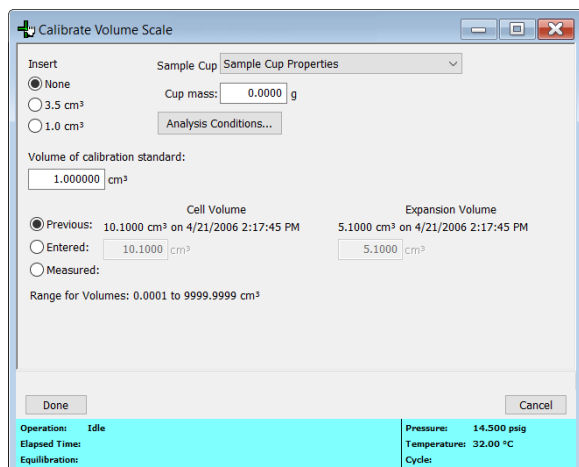

The screenshot shows the 'Calibrate Volume Scale' dialog box. It includes the following fields and options:

- Insert:** Radio buttons for 'None' (selected), '3.5 cm<sup>3</sup>', and '1.0 cm<sup>3</sup>'. An 'Analysis Conditions...' button is next to the radio buttons.
- Sample Cup:** A dropdown menu set to 'Sample Cup Properties'.
- Cup mass:** A text field containing '0.0000 g'.
- Volume of calibration standard:** A text field containing '1.000000 cm<sup>3</sup>'.
- Cell Volume:** Radio buttons for 'Previous:', 'Entered:', and 'Measured:'. The 'Previous:' option is selected. The 'Previous:' value is '10.1000 cm<sup>3</sup> on 4/21/2006 2:17:45 PM'.
- Expansion Volume:** Radio buttons for 'Previous:', 'Entered:', and 'Measured:'. The 'Previous:' option is selected. The 'Previous:' value is '5.1000 cm<sup>3</sup> on 4/21/2006 2:17:45 PM'.
- Range for Volumes:** A text field containing '0.0001 to 9999.9999 cm<sup>3</sup>'.
- Buttons:** 'Done' and 'Cancel' buttons at the bottom.
- Status Bar:** A cyan bar at the bottom showing 'Operation: Idle', 'Elapsed Time', 'Equilibration', 'Pressure: 14.500 psig', 'Temperature: 32.00 °C', and 'Cycle'.

3. Enter the volume of the calibration standard (located on the outside of the calibration standards case shipped with the instrument) in the *Volume of Calibration Standard* field.  
The value recorded on the case for a 10 cm<sup>3</sup> pycnometer is the sum of the two standards, and on a 350 cm<sup>3</sup> pycnometer, the sum of the three standards.
4. Select the *Measured* option.
5. Click **Analysis Conditions** to specify calibration parameters. Click **Replace** and select the file *Standard.anc*. The values in the current file will be replaced with those contained in the selected file. Click **OK**, then click **OK** again to return to the **Calibrate Volume Scale** window.

Calibration Analysis Conditions ×

Number of purges:  Replace

Purge fill pressure:  psig End equilibration by:

Number of cycles:   Rate  psig/min

Cycle fill pressure:  psig  Time  s

Use run precision

Percent full scale:  %

Enter a value between 0 and 999.

6. Click **Start** to begin the first phase of the calibration (volume offset). Status messages display until this phase is complete. When the phase has finished, a prompt display indicates to insert the calibration standard.
7. Remove the sample chamber cap, then remove the sample cup from the chamber. Place the cap back onto the chamber while placing the standard into the cup.
8. Tilt the sample cup and allow the standard to roll gently into the cup to prevent denting of the cup.

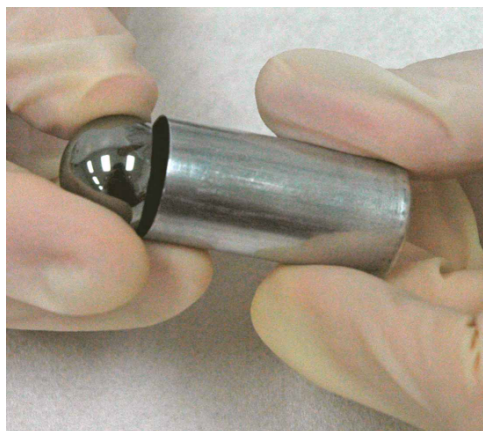

- one standard is shipped with the 1-, 100-, and 2000 cm<sup>3</sup> pycnometers
  - two are shipped with the 10 cm<sup>3</sup> pycnometer
  - three are shipped with the 350 cm<sup>3</sup> pycnometer
9. Remove the sample chamber cap, place the sample cup back into the chamber, and replace the cap. Turn the cap clockwise to tighten.
  10. Allow the standards to reach thermal equilibrium with the pycnometer.
    - Wait 10 minutes for 1- and 10 cm<sup>3</sup> pycnometer
    - Wait 15 minutes for the 100 cm<sup>3</sup> pycnometer
    - Wait 20 minutes for the 350 cm<sup>3</sup> pycnometer
    - 30 minutes for the 2000 cm<sup>3</sup> pycnometer

11. Click **Continue** to complete the second phase of the calibration (volume scale). Status messages display until the calibration is complete.
12. Click **Done** to accept the new values, then click **OK**.
13. Do not remove the standard from the sample chamber until the operation is verified. See [Verify Operation on page 10 - 11](#).

### Calibrate Volume Scale

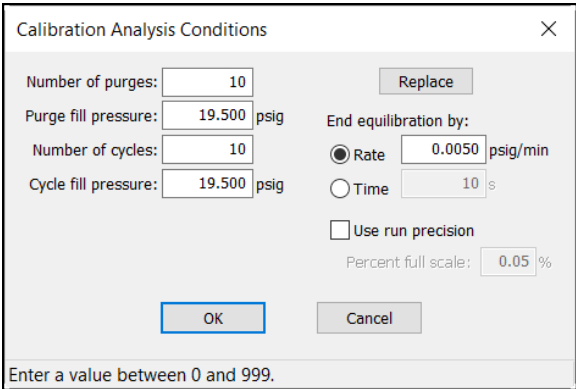
Field or Button	Description								
<b>Analysis Conditions</b>	<p>Specify conditions for the calibration.</p>  <p>Click <b>Replace</b> to replace the values with those from an existing Analysis Conditions file.</p>								
<b>Cell Volume</b>	Displays the current cell volume (without an insert), or the volume of the selected insert.								
<b>Continue [button]</b>	Place the standard into the sample cup and click <b>Continue</b> to complete the volume scale calibration.								
<b>Expansion Volume</b>	Displays the current expansion volume, and the date and time of calibration.								
<b>Insert</b>	<table border="0"> <tr> <td>1 cm<sup>3</sup> unit</td> <td>None, 0.1 cm<sup>3</sup></td> </tr> <tr> <td>10 cm<sup>3</sup> unit</td> <td>None, 3.5 cm<sup>3</sup></td> </tr> <tr> <td>1.0 cm<sup>3</sup> 100 cm<sup>3</sup> unit</td> <td>None, 35 cm<sup>3</sup>, 10 cm<sup>3</sup></td> </tr> <tr> <td>350 cm<sup>3</sup> and 2000 cm<sup>3</sup> units</td> <td>None, Large, Small</td> </tr> </table> <p>If <i>None</i> is selected, place an empty sample cup in the chamber.</p>	1 cm <sup>3</sup> unit	None, 0.1 cm <sup>3</sup>	10 cm <sup>3</sup> unit	None, 3.5 cm <sup>3</sup>	1.0 cm <sup>3</sup> 100 cm <sup>3</sup> unit	None, 35 cm <sup>3</sup> , 10 cm <sup>3</sup>	350 cm <sup>3</sup> and 2000 cm <sup>3</sup> units	None, Large, Small
1 cm <sup>3</sup> unit	None, 0.1 cm <sup>3</sup>								
10 cm <sup>3</sup> unit	None, 3.5 cm <sup>3</sup>								
1.0 cm <sup>3</sup> 100 cm <sup>3</sup> unit	None, 35 cm <sup>3</sup> , 10 cm <sup>3</sup>								
350 cm <sup>3</sup> and 2000 cm <sup>3</sup> units	None, Large, Small								

### Calibrate Volume Scale (continued)

Field or Button	Description
<b>Previous / Entered / Measured</b> [check box]	Select the method for calibrating the cell and expansion volumes.  <b>Previous.</b> Uses the current values.  <b>Entered.</b> Enables the fields for the cell and expansion volumes.  <b>Measured.</b> Measure the cell and expansion volumes using a reference standard.
<b>Start</b> [button]	Begins the first segment of the volume offset calibration.
<b>Volume of Calibration Standard</b> [text box]	The volume of the standard used for the previous calibration.
<div style="border: 1px solid green; padding: 5px;">  <p>For fields and buttons not listed in this table, see <a href="#">Common Fields and Buttons on page 3 - 2</a>.</p> </div>	



## VERIFY OPERATION

Verify operation of the pycnometer by performing an analysis on the calibration standard to ensure that the pycnometer is operating properly.

1. Go to **Unit [n] > Sample Analysis**.
2. Click **New** to create a new sample file.
3. Click **Replace all** and select the *refanly.smp* file. The values in the current file will be replaced with those contained in *refanly.smp*. Click **OK**.

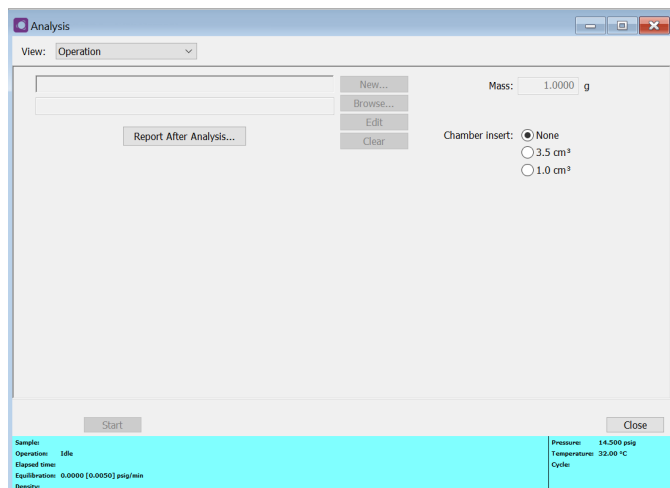

4. Click **Report After Analysis**. Select the *Report after analysis* option, then click **OK**.

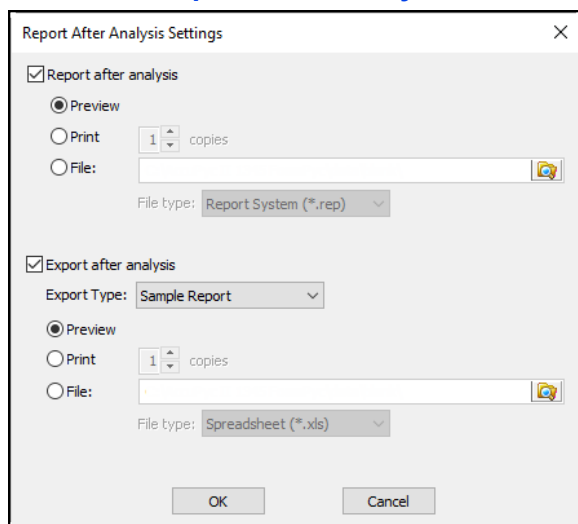

5. Click **Start** to begin the analysis.

6. Compare the value displayed for the average volume to the value recorded on the calibration standards case. These two values should agree plus or minus the tolerance obtained using the following calculation:

$$\text{Tolerance} = (\text{chamber volume} * 0.0003) + (\text{Value recorded on Standards case} * 0.0003)$$

Example: calculate the tolerance for a 10 cm<sup>3</sup> pycnometer with a value of 6.372242 cm<sup>3</sup> recorded on the case as :

$$\text{Tolerance} = (10 * 0.0003) + (6.372242 * 0.0003) = 0.003 + 0.0019116726 = 0.005 \text{ cm}^3$$

If the values do not agree, a leak may be indicated. Check the system for leaks. Then repeat steps 1 through 6. If the values continue to disagree, contact your Micromeritics Service Representative. See [Diagnostics using the Software on page 9 - 1](#).

7. Remove the standards and place them back into the case.

## **LOAD CALIBRATION FROM FILE**

### **Unit [n] > Calibration > Load from File**

Use to load a previously saved calibration file.

It is recommended that the current calibration settings be saved using **Unit [n] > Calibration > Save to File** prior to loading another calibration file. When loading a previously saved calibration file, a backup of the current file is created and saved as *[SN]ast.cal*. The backup file is overwritten each time a new one is created.



Changing the calibration may affect the analyzer's performance.

## **SAVE CALIBRATION TO FILE**

### **Unit [n] > Calibration > Save to File**

Use to save the current calibration settings to a backup file which can later be reloaded using the **Unit [n] > Calibration > Load from File** menu option.

The default file naming convention for calibration files can be used or the file name can be changed. The default file name of 0217-2013-04-25.CAL is interpreted as:

<b>0217</b>	is the analyzer serial number
<b>2013-04-25</b>	is the date the calibration file was saved
<b>.CAL</b>	is the file name extension

## ***CALIBRATE USING THE KEYPAD***

- [Calibrate Using the Software on page 10 - 1](#)

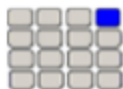

Use these instructions for keypad installations only. If a computer is attached to the module, skip this section. All setup functions will be done in the analysis software.

The pycnometer volume should be calibrated every time it is restarted. Cell volume and expansion volume in the set up parameters are updated automatically upon calibration. Run an analysis with an empty cup to see how close the average volume is to 0. It should be  $\pm 0.05\%$  of full scale. If it is not within  $\pm 0.05\%$  of full scale, calibration is required.

### ***CALIBRATE FUNCTION***

This command performs a full volume slope and offset calibration. Press **ALT + . (decimal)** to access the *Calibrate* function.

Display Text	Description
Calibration Type? Volume	Press <b>CHOICE</b> until the option is displayed, then press <b>ENTER</b> . <ul style="list-style-type: none"> <li>■ Volume</li> <li>■ Temperature</li> <li>■ Pressure</li> <li>■ Copy to an external device</li> <li>■ Load from an external device</li> <li>■ Reset Pressure Calibration</li> </ul>

**CALIBRATION DATA**

Display Text	Description
<b>Setup Type? Calibration Data</b>	Press <b>CHOICE</b> until <i>Calibration Data</i> is displayed, then press <b>ENTER</b> .
<b>Calibration Data Chamber Insert?</b>	Select <b>Yes</b> at the <i>Request insert</i> prompt in <i>Report Options</i> . Press <b>CHOICE</b> until the appropriate insert is displayed, then press <b>ENTER</b> . <ul style="list-style-type: none"> <li>■ None, 0.1 cm<sup>3</sup> (for 1 cm<sup>3</sup> unit)</li> <li>■ None, 3.5 cm<sup>3</sup>, 1.0 cm<sup>3</sup> (for 10 cm<sup>3</sup> unit)</li> <li>■ None, 35 cm<sup>3</sup>, 10.0 cm<sup>3</sup> (for 100 cm<sup>3</sup> unit)</li> <li>■ None, 650 cm<sup>3</sup>, 1300 cm<sup>3</sup> (for 2000 cm<sup>3</sup> pycnometer)</li> </ul>
<b>Calibration Data Cell Volume:</b>	Displays the cell volume determined during calibration. Cell volumes can also be entered at this prompt. Press <b>ENTER</b> .  The range is 0.01 to 999.0000 cm <sup>3</sup> .
<b>Calibration Data Expansion Volume:</b>	Displays the expansion volume determined during calibration. Press <b>ENTER</b> .  The range is 0.5 to 999.0000 cm <sup>3</sup> .

## CALIBRATE VOLUME

Place an empty cup into the sample chamber for **Cal1** (volume offset). If using an insert, place the insert and its appropriate sample cup into the sample chamber.

Display Text	Description
<b>Calibration Type? Volume</b>	Press <b>ENTER</b> to accept <i>Volume</i> (default) and display the next prompt.
<b>Calibrate Volume Chamber insert?</b>	<p>Press <b>CHOICE</b> until the appropriate insert is displayed, then press <b>ENTER</b>. <b>Yes</b> must be selected for the <i>Request Insert</i> prompt in <i>Report Options</i> for this prompt to display.</p> <ul style="list-style-type: none"> <li>■ None, 0.1 cm<sup>3</sup> (for 1 cm<sup>3</sup> unit)</li> <li>■ None, 3.5 cm<sup>3</sup>, 1.0 cm<sup>3</sup> (for 10 cm<sup>3</sup> unit)</li> <li>■ None, 35 cm<sup>3</sup>, 10.0 cm<sup>3</sup> (for 100 cm<sup>3</sup> unit)</li> <li>■ None, 650 cm<sup>3</sup>, 1300 cm<sup>3</sup> (for 2000 cm<sup>3</sup> pycnometer)</li> </ul>
<b>Calibrate Volume Volume of Cal Std:</b>	<p>Enter the volume of the calibration standard to be used in the calibration (located on the outside of the calibration standards case). Some pycnometers require and are shipped with multiple standards. In this instance, the value recorded on the case is the sum for all standards and is the one that should be entered at the prompt. Press <b>ENTER</b>.</p> <p>The range is 0.1 to 999.0000 cm<sup>3</sup>.</p>
<b>Calibrate Volume [ENTER] to start</b>	Press <b>ENTER</b> to begin the calibration or <b>Alt + CLEAR</b> to cancel. The volume offset is calibrated first ( <b>Cal1</b> ). When the first calibration is complete, the pycnometer beeps three times and the next prompt is displayed.

Display Text	Description
<b>Insert Cal Std</b> <b>[ENTER] to start</b>	<p>Place the calibration standard in the cup in the sample cell chamber and replace the chamber cap. Press <b>ENTER</b> to calibrate the volume (<b>Cal2</b>). Calibration continues and operational status messages are continually displayed. After the operation is complete, the pycnometer returns to the <i>Reload</i> prompt.</p> <p>For best results, sample volume should be approximately equal to the volume of the calibration standard. Therefore, if calibrating the 10 cm<sup>3</sup> pycnometer for use with smaller sample volumes, use only one standard. If using one standard, enter half of the value at the <i>Volume of cal std</i> prompt. Press <b>Alt + CLEAR</b> to cancel the operation.</p>

## RESET PRESSURE CALIBRATION



Contact a Micromeritics Service Representative and schedule a proper pressure calibration since data accuracy may be compromised.

This option can be used when the pressure is suspected of not being reported correctly by the analyzer. For example: a zero, negative, or unreasonably high reading is being consistently reported. Resetting to nominal may restore normal pressure readings but a proper calibration should be performed.

Display Text	Description
<b>Calibration Type?</b> <b>Reset Pressure Cal</b>	Press <b>CHOICE</b> until the desired option is displayed, then press <b>ENTER</b> .
<b>Reset Pressure cal?</b> <b>[Yes / No]</b>	<p>Resets the pressure calibration to nominal values. Temperature and volume calibrations are not affected. Nominal values may be sufficient. Schedule a proper pressure calibration as soon as possible, then press <b>CHOICE</b>.</p> <p>Select <b>Yes</b> to reset the calibration to nominal values. Press <b>ENTER</b>.</p> <p>Select <b>No</b> to contact your Service Representative to schedule a proper pressure calibration. Press <b>ENTER</b>.</p>

## REVIEW CALIBRATION

The *Review* function reviews the results of the last calibration operation.

The sample cell volume and the expansion cell volume are used for calculating the sample volume. The cell volume and expansion volume are updated automatically when the pycnometer is calibrated.

The prompts that display during a review of calibration data depend on the options specified in *Setup > Analysis Parameters* and *Report Options*.

1. Press **Alt + 5** to display the *Chamber Insert* prompt from which the insert can be selected (if used).
2. Press **ENTER** to display the volume of the calibration standard. This volume can be edited from this prompt.
3. Press **ENTER** to display the *Which Chamber* prompt.
4. Press **CHOICE** to select whether to view the results for the sample chamber or the expansion chamber.
5. Press **ENTER** to display a prompt showing the starting time and date.
6. Press **ENTER** to display a prompt showing the ending time and date.
7. Press **ENTER** to display the first of the prompts containing data. The  $[n]$  in this example represents the cycle number.

Unit[n]	SN1234	10 cm <sup>3</sup>
	X - X - X	
Cell [n] = (volume)		
Dev [n] = (deviation)		

8. Continue pressing **ENTER** to view all of the data. Press **CHOICE** to exclude data from report calculations. An asterisk will display indicating that it will be excluded.
9. Press **SAVE** to return to the *Reload* prompt.
10. Press **Alt + 6** to print report results.

Display Text	Description
<b>Chamber insert?</b> (insert)	<p>Displays the insert selected for the calibration or <i>None</i> if an insert was not used. If the selection is incorrect, press <b>CHOICE</b> until the correct one is shown, then press <b>ENTER</b>.</p> <ul style="list-style-type: none"> <li>■ None, 0.1 cm<sup>3</sup> (for 1 cm<sup>3</sup> unit)</li> <li>■ None, 3.5 cm<sup>3</sup>, 1.0 cm<sup>3</sup> (for 10 cm<sup>3</sup> unit)</li> <li>■ None, 35 cm<sup>3</sup>, 10.0 cm<sup>3</sup> (for 100 cm<sup>3</sup> unit)</li> <li>■ None, 650 cm<sup>3</sup>, 1300 cm<sup>3</sup> (for 2000 cm<sup>3</sup> pycnometer)</li> </ul>



Display Text	Description
<b>Volume of Cal Std: (volume)</b>	Displays the volume of the calibration standard that was used for the calibration. Press <b>ENTER</b> .
<b>Which Chamber? (chamber type)</b>	<p>Select to view calibration data for the sample cell chamber or the expansion chamber. Press <b>CHOICE</b> until the chamber is displayed, then press <b>ENTER</b>.</p> <p>The chamber type options are <i>Cell volume</i> and <i>Expansion volume</i>.</p>
<b>Start: (time) (date)</b>	<p>Displays the time and date the calibration began. Press <b>ENTER</b>.</p> <p style="text-align: center;">Time: HH:MM:SS Date: DD/MM/YY</p>
<b>End: (time) (date)</b>	<p>Displays the time and date the calibration completed. Press <b>ENTER</b>.</p> <p style="text-align: center;">Time: HH:MM:SS Date: DD/MM/YY</p>
<p><b>Cell[n] = (volume) Dv[n] = (deviations)</b></p> <p>or</p> <p><b>Exp[n] = (volume) Dv[n] = (deviations)</b></p>	<p>Displays the <i>Volume</i>, depending on the chamber type selected (<i>Cell volume</i> or <i>Expansion volume</i>).</p> <p>[n] represents the cycle number.</p> <p>Press <b>CHOICE</b> to exclude the displayed density (or volume) from the calculated average. An asterisk next to the density indicates it has been excluded. Press <b>CHOICE</b> again to remove the asterisk and have it included.</p> <p>Each time <b>CHOICE</b> is pressed to exclude or include the value. A new deviation is calculated and displayed.</p> <p>Press <b>ENTER</b> to view the values for the next cycle.</p> <p>Press <b>SAVE</b> to return to the <i>Reload</i> prompt. Press <b>SAVE</b> to automatically recalculate collected data and add all data reduction messages back into the queue.</p>

## CALIBRATE TEMPERATURE

This operation typically is performed by a Micromeritics Service Representative.

Press **Alt + .**, then press **CHOICE** until *Temperature* is displayed.

Display Text	Description
Calibrate Temperature Temperature:	Enter the temperature obtained from a reference temperature sensor. Press <b>ENTER</b> to automatically return to the <i>Reload</i> prompt. Press <b>ALT + CLEAR</b> to cancel the operation.

## ZERO THE PRESSURE TRANSDUCER & CHAMBER VOLUME

The pressure transducer zeroes automatically before each cycle in an analysis or calibration; therefore, it is not necessary to zero the unit for these operations. Typically, this function is not required unless manually performing analyses for an extended period of time.

Press **Alt + 0** to access the Zero function.

Display Text	Description
Zero Type? Pressure	Allows zeroing of the pressure transducer or the volume offset. Press <b>CHOICE</b> until the option is displayed, then press <b>ENTER</b> . If choosing <i>Pressure</i> , the next prompt is not displayed. Choices are <i>Pressure</i> and <i>Volume</i> . Ensure the sample chamber is empty if selecting <i>Volume</i> .
Zero Volume? Chamber insert? None  <i>Does not display for Pressure</i>	Displays when <i>Volume</i> is selected. Select <b>Yes</b> at the <i>Request insert</i> prompt in <i>Report Options</i> . Press <b>CHOICE</b> until the appropriate insert is displayed, then press <b>ENTER</b> . <ul style="list-style-type: none"> <li>■ None, 0.1 cm<sup>3</sup> (for 1 cm<sup>3</sup> unit)</li> <li>■ None, 3.5 cm<sup>3</sup>, 1.0 cm<sup>3</sup> (for 10 cm<sup>3</sup> unit)</li> <li>■ None, 35 cm<sup>3</sup>, 10.0 cm<sup>3</sup> (for 100 cm<sup>3</sup> unit)</li> <li>■ None, 650 cm<sup>3</sup>, 1300 cm<sup>3</sup> (for 2000 cm<sup>3</sup> pycnometer)</li> </ul>
Zero Volume [ENTER] to start [ESCAPE] to cancel  or  Zero Pressure [ENTER] to start [ESCAPE] to cancel	Press <b>ENTER</b> to begin the zero operation or <b>Alt + CLEAR</b> to cancel the operation.  If zeroing the <i>Volume</i> , the purges and cycles specified in the current analysis parameters are used to calculate the volume offset.  After the operation is complete, the pycnometer returns to the <i>Reload</i> prompt.

### LOAD CALIBRATION DATA FROM A USB MEDIA

Display Text	Description
Calibration Type? Load from USB Stick	Press <b>CHOICE</b> until the option is displayed. Press <b>ENTER</b> .
Insert USB stick and press [ENTER]	Insert the USB device into the USB connector on the rear panel of the unit. Press <b>ENTER</b> .
Local cal for SN:	Key in the serial number. Press <b>ENTER</b> .
Calibration for SN (nnnn) copied	Display the unit for which calibration information has been copied.
Remove USB stick	Remove the USB media. The system automatically returns to the <i>Reload</i> prompt. This prompt appears immediately after the <i>Calibration for SN</i> prompt.

### COPY CALIBRATION DATA TO A USB MEDIA

Display Text	Description
Calibration Type? Copy to USB Stick	Press <b>CHOICE</b> until the option is displayed. Press <b>ENTER</b> .
Insert USB stick and press [ENTER]	Insert the USB device into the USB connector on the rear panel of the unit. Wait a few seconds, then press <b>ENTER</b> .
Calibration for SN (nnnn) copied	Display the unit for which calibration information has been copied.
Remove USB stick	Remove the USB media. The <i>Reload</i> prompt displays. This prompt appears immediately after the <i>Calibration for SN</i> prompt.

**Blank Page**

---

## 11 HARDWARE

Parts and accessories can be found online at [www.Micromeritics.com](http://www.Micromeritics.com).

### ADD ANALYSIS MODULE TO CONTROL MODULE

- [Add Analysis Modules to a Temperature Controlled Module on page 14 - 2](#)

Additional analysis modules provide the ability to increase productivity and/or provide a means for analyzing different size samples concurrently. Multiple analysis modules can be connected to an integrated controller / analysis module.



If installing an external TEC module, it is suggested that the TEC system be installed first, to allow time for temperature to stabilize at the desired temperature, while the AccuPyc is being installed. The TEC module has a separate power cord and external power supply.

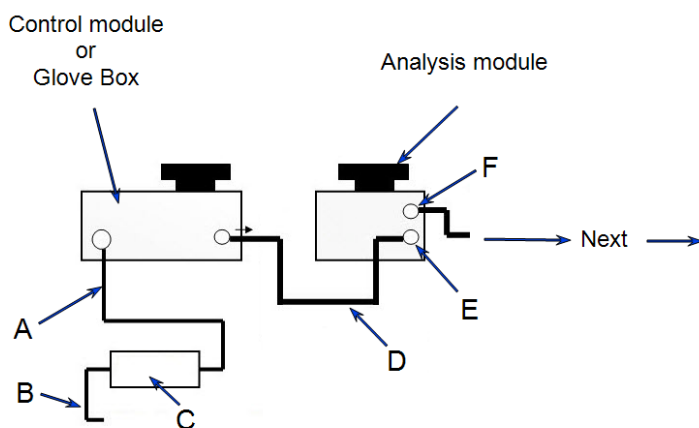

- A. Hardwired 8 pin mini-DIN power cable for external power supply.
- B. Separate power cord for external power supply. Connect cable to wall outlet.
- C. External power supply.
- D. Mini DIN cable for power and serial control data.
- E. Module connection - 8 pin mini-DIN IN port to connect the control module or previously connected analysis module (not shown).
- F. Module connection - 8 pin mini-DIN OUT port to connect next analysis module.



Exit the application before powering off the analyzer.

1. Power OFF the control module.
2. Connect one external power supply cable to the back of the new unit and another external power supply cable to each power adapter.

3. Connect a power cable to each external power supply.
4. Attach one end of the DIN cable (provided in the module accessories kit) to the connector labeled *Module Connection* on the back of the new unit.
5. Attach the other end of the DIN cable to the separate power adapter.
6. Attach the hardwired power adapter cable to the lower connector labeled *Module Connection* on the back of the analysis module.
7. Plug the external power supply cables into electrical wall outlets.
8. Power ON the control module. If running the application software, start the application.
9. Verify the unit is recognized:

- If running the application software, *Unit [n]* menus are added to the menu bar for each analysis module connected.

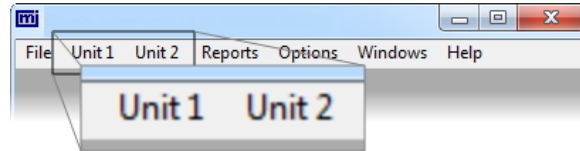

- If using the keypad for analysis, press **Alt + CHOICE + 2** to access the additional analysis module. *Unit [n]* appears in the upper left corner of the display.

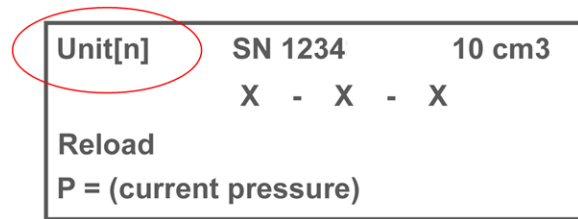

10. Calibrate the pycnometer. See [Calibrate Using the Keypad on page 10 - 14](#) or [Calibrate Using the Software on page 10 - 1](#).

## ANALYTICAL BALANCE

The analytical balance tested by Micromeritics is Scientec model #ZSA120.



An analytical balance can be connected to a serial port on the computer and used to transfer the sample's mass directly to the AccuPyc II application.

1. Connect the analytical balance to the RS232 port on the rear panel of the analyzer.
2. Go to **Options > Configure Balance** to connect and set up an RS232 balance to the analyzer.

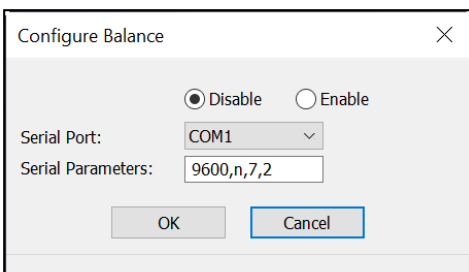

### Configure Balance

Field or Button	Description
Enable / Disable	Select to enable or disable the attached balance.
Serial Parameter	Used to set the baud rate, parity, data bits, and stop bits. This field should not require modification from the default values.
Serial Port	Select which serial port is used to connect the balance to the analyzer.

## ***BRIGHTNESS CONTROL***



To adjust the display brightness:

1. Insert a small flat head screwdriver into the opening.
2. Rotate the screwdriver until it engages in the slot, then turn clockwise to darken and counterclockwise to lighten.



---

## ***HANDLING SYSTEM COMPONENTS***

### ***CALIBRATION STANDARD***

- Wear latex or nitrile, powder-free gloves to prevent transfer of oil from hands.
- Do not drop the standard into the sample cup. Roll the standard into the cup to prevent damage.
- Always return the standards to the case. Standards are unit specific.

### ***SAMPLE CHAMBER CAP***

- Wear latex or nitrile, powder-free gloves to prevent transfer of oil from hands.
- Keep the cap on the sample chamber except when inserting or removing the sample cup.



When left uncapped, the sample chamber temperature may become unstable and/or water vapor will adsorb on the inner surface of the chamber. Either of these conditions can affect analysis results.

- Avoid laying the chamber cap on a work surface. Debris may collect on the greased surface of the O-ring which can also affect analysis results.
- When multiple analysis modules are connected, never interchange sample chamber caps. Caps are unit specific.

## RS232 PIN ASSIGNMENT

The AccuPyc is a standard DTE device. The RS232 port can be used to connect an analytical balance for transfer of sample weight, or for transmitting data to a computer. The receiving device must be configured to interface with the RS232 pin assignments. Any signals that are not listed in the *RS232 Pin Assignment* table are ignored.

### RS232 Pin Assignments

Pins	Signal	Description	Data Direction
2	RXD	Receive Data	Into AccuPyc
3	TXD	Transmit Data	From AccuPyc
4	DTR	Data Terminal Ready	From AccuPyc
5	GND	Ground	N/A
6	DSR	Data Set Ready	Into AccuPyc

The AccuPyc uses the DTR and DSR signals for hardware flow control. Ensure that the serial device provides these signals. For example, if attaching to a computer (also a DTE device), use a null modem cable which includes the designated signals. If transmission problems occur, ensure that the signals are set up properly. If the signals are correctly configured, contact the receiving device manufacturer for assistance.

## 12 MAINTENANCE AND TROUBLESHOOTING

---

Parts and accessories can be found online at [www.Micromeritics.com](http://www.Micromeritics.com).



Improper handling, disposing of, or transporting potentially hazardous materials can cause serious bodily harm or damage the instrument. Always refer to the MSDS when handling hazardous materials. Safe operation and handling of the instrument, supplies, and accessories is the responsibility of the operator.



Do not modify this instrument without the authorization of a Micromeritics service personnel.



When lifting or relocating the instrument, use proper lifting and transporting devices for heavy instruments. Ensure that sufficient personnel are available to assist in moving the instrument. The AccuPyc 1345 weighs approximately 7.9 - 26 kg (17 - 51 lb) depending on configuration.



Use of a power cord or power supply not provided with the instrument could cause personal injury or damage to the equipment. If a replacement is needed, contact your Micromeritics Service Representative. Detachable power supply cords with an inadequate rating could cause significant instrument damage or physical harm.

Do not add anything between the power cord and the power source that would compromise the earth ground.

Do not remove or disable the grounding prong on the instrument power cord.

The analyzer has been designed to provide efficient and continuous service; however, certain maintenance procedures should be followed to obtain the best results over the longest period of time. When unexpected results occur, some common operational problems not indicated on the window and their respective causes and solutions are provided.

Log in to your [customer portal](#) to access error messages. Parts and accessories can be found online at [www.Micromeritics.com](http://www.Micromeritics.com).

### **Power indicator did not illuminate when analyzer was powered ON.**

*Cause A:* Power or DIN cables not fully inserted.

*Action A:* Verify cable connections and connect any loose cable ends into proper outlets.

*Cause B:* No power at outlet.

- Action B:* Test the outlet. If there is no power, contact electrician.
- Cause C:* Plug prongs bent so that contact not made at outlet.
- Action C:* Unplug the power cable and re-plug into outlet. If indicator does not illuminate, have electrician adjust prongs or replace outlet or plug.
- Cause D:* Power cord damaged.
- Action D:* Have electrician check cord using test meter. Replace if defective.
- Cause E:* Loose internal connection, broken wire, or failure of internal power supply.
- Action E:* Contact a Micromeritics Service Representative for repair or replacement information.

### **Specified pressure not reached or maintained.**

- Cause A:* Chamber cap not properly closed.
- Action A:* Close chamber cap by turning fully clockwise.
- Cause B:* Chamber cap contains dust or debris or the O-ring is not properly greased.
- Action B:* Using a lint free tissue, clean the chamber cap and the rim of the cell chamber. Lightly grease the chamber cap O-ring. See [Chamber Cap O-Ring on page 12 - 5](#).
- Cause C:* The chamber cap O-ring is not properly seated.
- Action C:* Check the chamber cap. Ensure that the O-ring is properly seated and that it contains no scratches or cuts.
- Cause D:* The chamber cap O-ring is cut or scratched.
- Action D:* Replace the O-ring in the chamber cap. See [Chamber Cap O-Ring on page 12 - 5](#).
- Cause E:* Gas leaks in the cell chamber or expansion chamber.
- Action E:* Check the pycnometer for leaks. See [Check the Cell and Expansion Chambers for Leaks on page 12 - 7](#).
- Cause F:* The helium tank is low on gas or empty. Tank pressure should be at least 200 psi above regulator pressure.
- Action F:* Check tank. Minimum recommended pressure is 200 psig above regulator pressure. See [Regulator Pressure on page 12 - 15](#).
- Cause G:* The shut-off valve on the gas cylinder is closed.
- Action G:* Ensure that the valve is open.
- Cause H:* The Zero offset (of pressure transducer) is too low.

*Action H:* Check offset by opening chamber cap. If pressure is negative (displayed on instrument schematic), run a new zero offset. See [Zero the Pressure Transducer & Chamber Volume on page 10 - 20](#).

*Cause I:* Dust filter on 2000 cm<sup>3</sup> unit is clogged or leaking to atmosphere.

*Action I:* Clean the dust filter. See [Clean the Dust Filter on page 12 - 9](#).

### **Helium drained from tank.**

*Cause A:* Leaks in the gas line connection.

*Action A:* Pressurize the system. Close, then open the gas cylinder shut-off valve. If the needle on the pressure gauge falls abruptly, a leak in the gas line connections may be indicated. Check all gas line connections.

*Cause B:* Pycnometer was left in Manual mode with all the valves open or the fill valve open and chamber cap off.

*Action B:* Close all valves, then attach a new tank of helium.

### **Unit will not equilibrate, or results are not reproducible.**

*Cause A:* Sample outgassing.

*Action A:* Prior to analysis, remove moisture and contaminants from the sample. See [Prepare and Load a Sample on page 6 - 1](#).

*Cause B:* Dust filter on 2000 cm<sup>3</sup> unit is clogged or leaking to atmosphere.

*Action B:* Clean the dust filter. See [Clean the Dust Filter on page 12 - 9](#).

*Cause C:* Defective cap O-ring.

*Action C:* Check cap O-ring for defects. Regrease or replace the O-ring, if necessary.

*Cause D:* Debris on valves.

*Action D:* With manual mode enabled and with the cap installed, open all valves. With helium flowing through the pycnometer, open and close the expansion valve repeatedly for approximately one minute. This will remove sample contamination, which may cause a leak, from the valve seat. Repeat the process for the vent valve with the inlet and expansion valves open.

## POWER

The AccuPyc is designed to operate with a power supply of 90-264V~ at 50/60Hz. Noise-free power of the correct voltage and frequency, with a safety earth ground, should be available through a standard wall receptacle. The power outlet should be able to supply 15 amps @ 100 or 115V~  $\pm 10\%$  or 7.5 amps @ 230V~  $\pm 10\%$ . There should also be sufficient outlets for all devices.



The external power adapter required for the AccuPyc is Micromeritics' part number 003-40054-00. Use of any other power adapter could damage equipment and/or cause harm to the operator. The AccuPyc is intended to be powered from the output of the approved power adapter rated Class III, manufacture by TRUMPower, P/N TSA42-D21 (R1). Micromeritics supplies a suitably rated approved power supply cord appropriate for the applicable country with the power adapter.



The analyzer and peripheral devices **must** be installed on their own dedicated power line. Other devices — such as motors, generators, or ovens — **should not** be placed on the same power line.



Replacement power supply cords must be rated for the specifications stated above.

## ***CHAMBER CAP O-RING***

The cell chamber cap contains an O-ring that requires routine maintenance. The chamber cap O-ring should be greased at the beginning of each period of use.

Fine fibers and particles between the O-ring and its sealing surfaces can cause leaks, as can scratches or cuts in the O-ring or in the metal surfaces.

## ***GREASE THE CHAMBER CAP O-RING***

1. Turn the chamber cap counter-clockwise and lift it from the chamber.
2. Place the chamber cap on a clean surface with the O-ring side exposed.
3. Use a small drop of Dow Corning high vacuum grease (or equivalent).
4. Distribute the grease evenly and completely around the O-ring groove.



5. Replace the chamber cap.
6. If recalibrating the pycnometer, allow the pycnometer to warm up for 30 minutes before calibrating.

## REPLACE THE CHAMBER CAP O-RING

1. Use a pointed tool and carefully remove the O-ring from its groove in the cap. A small niche is provided at the groove for placement of the tool.



Do not to scratch the metal surface of the chamber cap. Scratches could result in an imperfect seal.

2. Clean the groove in the chamber cap using a small brush or clean, lint-free tissue moistened with isopropyl alcohol.
3. Allow the chamber cap to dry thoroughly.
4. Use a small drop of Dow Corning high vacuum grease (or equivalent).
5. Grasp the O-ring with the two greased fingers. Distribute the grease evenly and completely around the O-ring.



Apply the grease sparingly. Too much grease may alter cell volume while too little grease results in an imperfect seal and leaks.

6. Place the O-ring back into the groove on the cap and, with the greased index finger, gently press it back into position.
7. Ensure the O-ring groove is properly greased. See [Grease the Chamber Cap O-Ring on the previous page](#).
8. Replace the chamber cap.



## CHECK THE CELL AND EXPANSION CHAMBERS FOR LEAKS

This procedure should be performed in a temperature-stable environment after the pycnometer has been allowed to warm for at least two hours. Before performing this procedure, check the chamber cap to ensure that it is not the source of leaks. It should be free from particles, the O-ring should be properly seated, and should not contain excessive grease.

### CHECK FOR LEAKS USING THE SOFTWARE



Before performing this procedure, check the chamber cap to ensure that it is not the source of leaks. It should be free from particles, the O-ring should be properly seated, and it should not contain excessive grease.

#### Unit [n] > Diagnostics

- [Diagnostics using the Software on page 9 - 1](#)

### CHECK FOR LEAKS USING THE KEYPAD



Before performing this procedure, check the chamber cap to ensure that it is not the source of leaks. It should be free from particles, the O-ring should be properly seated, and it should not contain excessive grease.

Check the cell and expansion chambers for leaks.

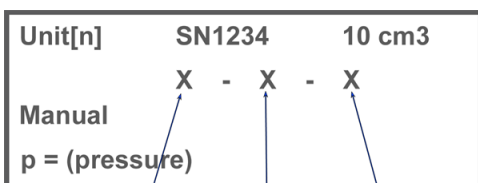

- A. Fill valve
- B. Expansion valve
- C. Vent valve

1. Allow the pycnometer to equilibrate thermally in a room with a stable temperature.
2. Press **Alt + 1** to enter Manual mode.

3. If the system was previously open, manually purge the system before proceeding:
  - a. Press **8** to open the *Expansion* valve and **9** to close the *Vent* valve; **X - O - X**.
  - b. Press **7** to open the *Fill* valve. Once the sample chamber fills to the appropriate pressure, press **7** to close the *Fill* valve.
  - c. Press **9** to open the *Vent* valve; **X - O - O**.
  - d. Repeat this procedure two or three times.
  - e. Press **8** to close the *Expansion* valve; **X - X - O**.
4. Press **7** to open the *Fill* valve; **O - X - O**.
5. Fill the sample chamber to 19.5 psig.
6. Press **7** to close the *Fill* valve; **X - X - O**.
7. Observe the pressure display. After an equilibration period (about 20 to 30 seconds), the pressure should not decrease more than 0.007 psig (0.048 kPag) or increase more than 0.02 psig (0.14 kPag) in a two minute span.
  - If the pressure does not decrease more than 0.007 psig (0.048 kPag) or increase more than 0.02 psig (0.14 kPag) in a two minute span, proceed to step 8.
  - If the pressure decreases more than 0.007 psig (0.048 kPag) or increases more than 0.02 psig (0.14 kPag) in a two minute span, temperature instability or a leak may be indicated. Vent the system, then repeat steps 4 through 7 several times to verify that a leak is indicated. If a leak is indicated, call a Micromeritics Service Representative.
8. Press **9** to close the *Vent* valve, **8** to open the *Expansion* valve, and **7** to open the *Fill* valve; **O - O - X**.
9. Fill the chambers to 19.5 psig.
10. Press **7** to close the *Fill* valve; **X - O - X**.
11. Observe the pressure display. After an equilibration period (about 20 to 30 seconds), the pressure should not decrease more than 0.007 psig (0.048 kPag) or increase more than 0.02 psig (0.14 kPag) in a two minute span.

If the pressure decreases more than 0.007 psig (0.048 kPag) or increases more than 0.02 psig (0.14 kPag) in a two minute span, temperature instability or a leak may be indicated. Vent the system, then repeat steps 8 through 11 several times to verify that a leak is indicated. If a leak is indicated, call a Micromeritics Service Representative.

## CLEAN THE DUST FILTER



Applicable only to 2000 cm<sup>3</sup> units and 100 cm<sup>3</sup> high pressure units.

Dust from the sample may be carried into the instrument plumbing. A dust filter protects the valves, minimizing valve leaks.

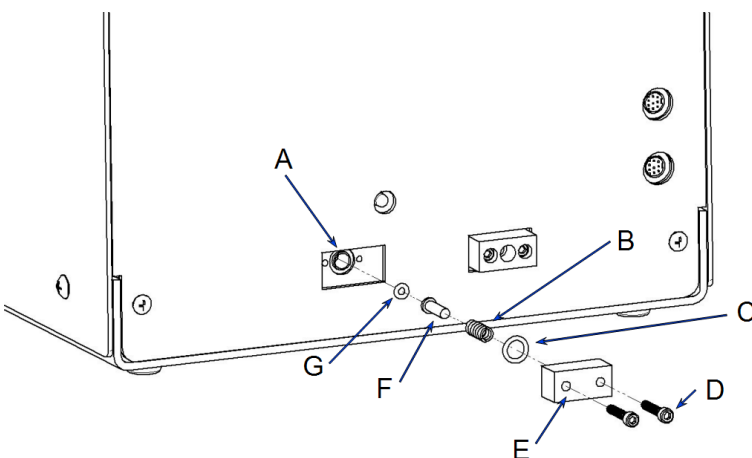

- A. Filter port
- B. Spring
- C. O-ring (size 011)
- D. Retaining screws
- E. Cover plate
- F. Filter
- G. O-ring (size 006)

1. Press **Alt+1** to enter Manual mode.
2. Close the *Fill* valve. Open the *Expansion* and *Vent* valves to ensure that the system is not under pressure.
3. At the lower rear of the instrument, remove the two screws which hold the dust filter cover and remove the cover plate.
4. Remove the spring and the filter. Remove the small O-ring inside the filter port.
5. Clean all parts with alcohol. The filter may require sonication to dislodge dust. It should be replaced if it becomes severely clogged.
6. Inspect the O-rings before re-assembly. A very thin coating of vacuum grease may be used.
7. Re-assemble.
8. Check for leaks:
  - a. Fill the system with gas.
  - b. Open *Expansion* valve.
  - c. Check for leaks by applying a leak detecting liquid around the dust filter cover.

## ***CLEAN THE PYCNOMETER***

The exterior casing of the pycnometer may be cleaned using a clean, lint-free cloth, dampened with isopropyl alcohol (IPA), a mild detergent solution, a 3% hydrogen peroxide solution, or a detergent that is not corrosive to aluminum.



Do not immerse the pycnometer or the power cord in any liquids. Doing so could result in electrical shock to personnel or damage to the unit.



Do not allow liquid to penetrate the casing of the pycnometer. Doing so could result in damage to the unit.

## ***DECONTAMINATION OF THE PYCNOMETER***



Always wear personal protection equipment appropriate for the type and level of contamination.

In addition to following the instructions to clean the pycnometer, service personnel should use compressed air to decontaminate internal components.

## GUIDELINES FOR CONNECTING GASES



These instructions refer to the installation of a gas line, regulator, and gas cylinder for each type of gas used. Expansion kits or other accessories may be used in the lab. If so, special consideration should be given to these configurations when installing the gas lines.



Improper handling, disposing of, or transporting potentially hazardous materials can cause serious bodily harm or damage the instrument. Always refer to the MSDS when handling hazardous materials. Safe operation and handling of the instrument, supplies, and accessories is the responsibility of the operator.

- Place gas cylinders within 6 feet (2 m) of the gas inlets of the analyzer. Place the cylinders close enough to allow for proper connection at the analyzer inlet.

Using gas line extenders on gas cylinders located in remote areas may degrade gas quality and reduce pressure. Gas lines are typically five to six feet long.

Long gas lines, such as those used with gas cylinders placed in remote areas, must be evacuated for an extended period of time to remove ambient gases. When possible, avoid placing gas cylinders in remote locations. It is always best to have gas cylinders located near the analyzer
- Use a retaining strap (or other appropriate tether) to secure the gas cylinder.
- Always use the gas lines provided with the analyzer. It is very important that proper gas lines are used with the analyzer.
  - **Do not use** polymer tubing for the gas line.
  - **Do not use** flexible gas lines. Some flexible lines may appear to be appropriate, such as those with a herringbone covering, but the line may be coated internally with a polymer.
- Carefully route the gas lines from the cylinder to the analyzer avoiding overlapping or entangling gas lines. This will help avoid confusion when maintenance is required.
- Label the gas line at the analyzer inlet for proper identification and maintenance.
- Replace gas cylinders before gas is depleted. It is best to replace a gas cylinder when the pressure reads approximately 500 psi (3500 kPa) on the high pressure gauge. Contaminants absorbed to the walls of the cylinder will desorb as the pressure decreases.
- Ensure the gas cylinder is closed before connecting to the analyzer.

## ***REPLACE A GAS CYLINDER***

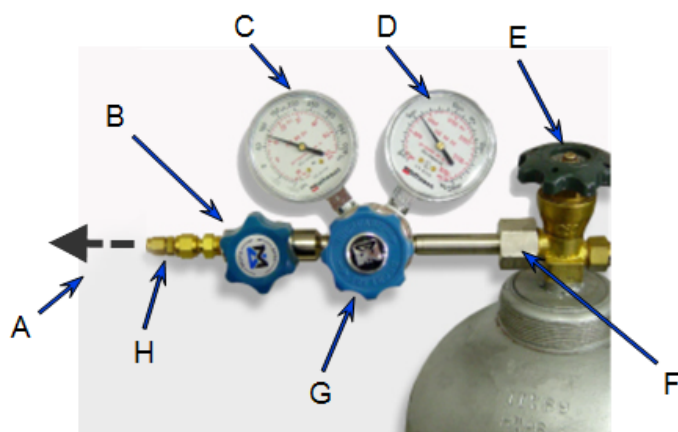

- A. Gas tubing to instrument
- B. Gas regulator shut-off valve
- C. Low pressure gauge
- D. High pressure gauge
- E. Gas cylinder shut-off valve
- F. Regulator connector nut
- G. Regulator control knob
- H. Brass reducer fitting

### **Disconnect a Depleted Gas Cylinder**

1. Close the regulator shut-off valve and gas cylinder shut-off valve by turning the knobs clockwise.
2. Disconnect the gas line from the regulator. Gas will be vented from the line. It is not necessary to disconnect the gas line from the analyzer inlet if the cylinder will be replaced immediately with one of the same type.
3. Open the gas regulator shut-off valve by turning the knob counter-clockwise. Gas will be vented from the regulator.
4. Turn the regulator control knob clockwise to open and vent any remaining gas. Both gauges should read at or near zero. If not, make sure the gas regulator shut-off valve is open.
5. Close the regulator by turning the control knob counter-clockwise.
6. Use an appropriate wrench to loosen the nut at the regulator connector nut then remove the regulator from the cylinder.
7. Replace the protective cap on the depleted cylinder. Disconnect the retaining strap and move the cylinder to an appropriate location.

## Connect a Gas Cylinder

### Regulator Pressure Settings

Analyzer Series	Gauge should indicate
3Flex	15 psig (103 kPag)
AccuPyc	25 psig (172 kPag)
ASAP	15 psig (103 kPag)
AutoChem	15-18 psig (103 - 124 kPag)
AutoPore	50-60psig (345 - 404 kPag)
Gemini	15-18 psig (103 - 124 kPag)
MIC SAS II	15-20 psig (103-138 kPag)
TriStar	15-18 psig (103 - 124 kPag)



Exceeding the maximum recommended air pressure could cause personal injury or damage the instrument.

1. Use an appropriate cylinder wrench to remove the protective cap from the replacement gas cylinder. Place the protective cap in a secure location. It will be needed to recap the gas cylinder when it is depleted and replaced.
2. Attach the gas regulator to the gas cylinder connector. Hand tighten the nut, then use an appropriate wrench to tighten an additional 3/4 turn.



Over-tightening the fitting may cause a leak.

3. Check for leaks at the high pressure side of the regulator and in the connector.
  - a. Turn the regulator control knob fully counter-clockwise.
  - b. Slowly open the gas cylinder shut-off valve, then quickly close it.
  - c. Observe the pressure on the high pressure gauge for approximately one minute:
    - If the pressure is stable, proceed with the next step.
    - If the pressure decreases, tighten the regulator connector nut until it becomes stable. If the pressure does not remain stable, remove the regulator and clean all contacts at the regulator connection, then reinstall the regulator.
4. Purge the lines and set the regulator pressure.
  - a. If the gas line is not connected to the regulator and the instrument connect it now.
  - b. Fully open the gas bottle shut-off valve and the gas regulator shut-off valve.
  - c. Under manual control, open the fill, expand, and vent val

- d. Adjust the regulator pressure control knob until the Purge fill or Cycle fill pressure, whichever is higher, is shown on the regulator display.
- e. Allow gas to flow for 30 seconds.
- f. Close the fill, expand, and vent valves.
- g. Turn the regulator control knob clockwise to increase pressure by 2 psi (15 kPa).



## REGULATOR PRESSURE



Tank pressure should be at least 200 psi above regulator pressure. Pressures less than 200 psig indicate the tank is low on gas. Analyses are terminated automatically if gas is depleted.

For a high pressure sample chamber configuration, set regulator pressure 20 psi above cycle and fill pressure.

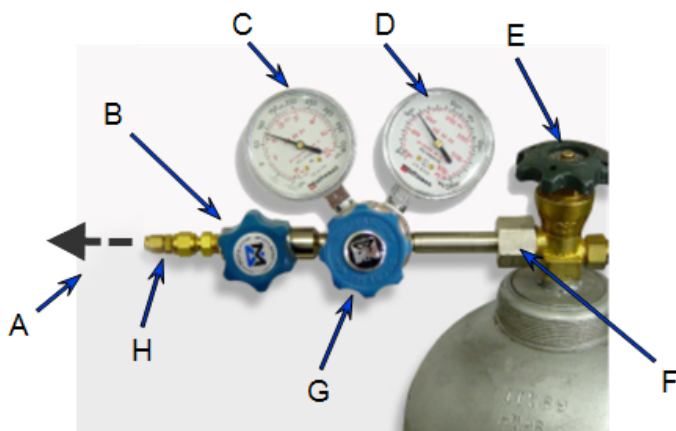

- A. Gas tubing to instrument
- B. Gas regulator shut-off valve
- C. Low pressure gauge
- D. High pressure gauge
- E. Gas cylinder shut-off valve
- F. Regulator connector nut
- G. Regulator control knob
- H. Brass reducer fitting

## SET REGULATOR PRESSURE WITH THE SOFTWARE

The *Purge fill* and *Cycle fill* pressures are specified in *Analysis Conditions*. Set the regulator pressure at the higher of the two, plus 2.0 psig. For example; if the *Purge fill* pressure is set to 19.500 psig (134.445 kPag) and the *Cycle fill* pressure as 19.000 psig (131.000 kPag), set the regulator pressure at 21.500 psig (148.237 kPag).

1. Go to **Unit [n] > Enable Manual Control**. Ensure a checkmark displays to the left of the menu item. If the analyzer schematic does not display, go to **Unit [n] > Show Instrument Schematic**.
2. On the schematic, right click the *Expansion* and *Vent* valves and select *Open* for both. Then open the *Fill* valve.
3. Adjust the regulator pressure control knob until the *Purge fill* or *Cycle fill* pressure, whichever is higher, is shown on the regulator display. Tank pressure should be at least 200 psi above regulator pressure.
4. On the schematic, close the *Fill* valve, then increase the regulator pressure by 2.0 psig (13.8 kPag).
5. Allow the pressure in the pycnometer to drop below 2.0 psig, then close the *Expansion* and *Vent* valves.

## ***SET REGULATOR PRESSURE WITH THE KEYPAD***

The *Purge fill* pressure and *cycle fill* pressure are specified using *Setup > Analysis Parameters*. Set the regulator pressure at the higher of the two (plus 2.0 psig). For example; if the *purge fill* pressure is specified as 19.500 psig and the *cycle fill* pressure as 19.000 psig, then set the regulator pressure at 21.500 psig.

1. Press **Alt + 1** to enter Manual mode.
2. Press **8** (*EXPAND*) and **9** (*VENT*) to open the expansion and vent valves; the display will show: **X - O - O**
3. Press **7** (*FILL*) to open the *fill* valve; the display will show: **O - O - O**
4. Adjust the regulator pressure control knob until the *Purge fill* or *Cycle fill* pressure, whichever is higher, is shown on the regulator display.
5. Press **7** to close the *Fill* valve, then increase the regulator valve by 2.0 psig. The display will show: **X - O - O**.
6. Allow the pressure in the pycnometer to drop below 2.0 psig, then press **8** and **9** to close the *Expansion* and *Vent* valves. The display will show: **X - X - X**
7. Press **SAVE** to return to the *Reload* prompt.

## ***RECOVER FROM A POWER FAILURE***

Setup parameters and collected data are recorded by the pycnometer in case of a power failure. These settings will be available when power is restored. If an automatic operation was in progress when the power failure occurred, it will be canceled when the pycnometer restarts.



Even though the pycnometer saves data during a power failure, any operation should be restarted to ensure complete results.

## ***RESET THE PYCNOMETER***

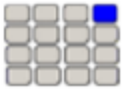

Use these instructions for keypad installations only. If a computer is attached to the module, skip this section. All setup functions will be done in the analysis software.

There are two ways to reset the Pycnometer.

- Hold the **.**(decimal) key on the keypad during power ON. This erases data and setup parameters except for printer and network settings.
- Hold **5** on keypad during power ON. This resets setup parameters, as well as printers and network settings.

## ***POWER INSTRUMENT ON AND OFF***



DO NOT connect or disconnect cables when the instrument is powered ON.



Do not power off the analyzer while initialization is in progress. Doing so may damage the instrument.



It is important that a constant temperature be maintained inside the unit because a change in temperature could alter analysis results. We recommend that the pycnometer remain powered on at all times to maintain thermal stability.

When the analyzer is powered on, after a few seconds, the system vents automatically and the green indicator light on the front panel illuminates. Allow approximately 30 minutes for the analyzer to warm before performing analyses. For analyses that require very precise results, allow the analyzer to warm a minimum of two hours. If running the analyzer with a computer:

Power ON the equipment in the following order:

If running the analyzer with a computer:

1. Computer
2. Monitor
3. Printer
4. Analyzer

If running the analyzer without a computer:

1. Analyzer

Power OFF the equipment in the following order:

If running the analyzer with a computer:

1. Analyzer. Allow any analyses in progress to complete prior to powering off.
2. Exit the analysis program. Failure to do so could result in loss of data.
3. Computer
4. Monitor
5. Printer

If running the analyzer without a computer:

1. Allow any analyses in progress to complete prior to powering off the analyzer.
2. Printer
3. Analyzer

## ***SERVICE TEST MODE***

### ***Options > Service Test Mode***

Service Test Mode is a password protected option used to perform certain service tests with the assistance of a trained Micromeritics Service Representative. This password is supplied by your Micromeritics Service Representative.

If a menu item is grayed out, it is usually an indication that Service Test Mode is required.

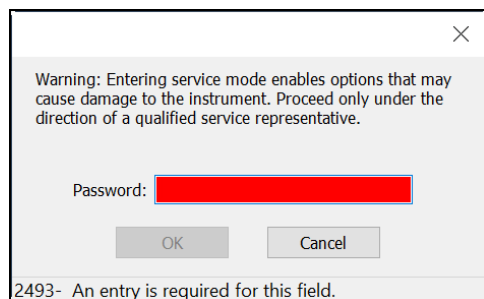

To exit Service Test Mode, go to ***Options > Service Test Mode*** and deselect the ***Service Test Mode*** option or close the application.

## ***PARTS REPLACEMENT***

- To ensure proper form, fit, and function, consumables may be purchased from Micromeritics.
- Repair parts are proprietary and must be obtained from Micromeritics.

**Blank Page**

---

## 13 TEC MODULE

This AccuPyc system has been modified to provide temperature control from 15 to 36 °C. The system uses a thermoelectric control (TEC) system to heat or cool the AccuPyc. The temperature is controlled using a digital temperature controller and a separate power system from the AccuPyc.

It is suggested that the TEC system be installed first, to allow time for temperature to stabilize at the desired temperature, while the AccuPyc is being installed.

### SET THE TEC TEMPERATURE

1. Power on the TEC module. The power switch is located near the power inlet.

The digital display of the temperature controller will show a test message while it starts up. When the test message stops flashing, the current temperature displays. If the current temperature and a message such as *ErAt* displays, press the **P** (Program) key on the front panel of the controller. The *ErAt* message should stop and only the current temperature will display.

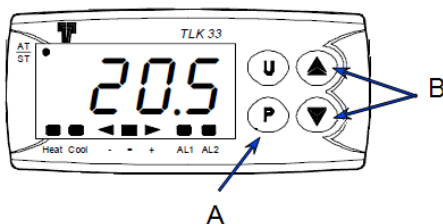

- A. Program keys
- B. Up and down keys

2. Press **P**. *SP 1* displays followed by the current setpoint (*SP 1*). Use the **Up** or **Down** key to set the temperature.
3. Press **P** to accept the temperature. The controller will now start heating or cooling to achieve the setpoint



The TEC module uses a fan to remove heat. The fan is located on the underside of the instrument. The fan pulls air into the instrument and the air is exhausted through ventilation slots on the rear panel. The exhaust slots must remain unobstructed.

Do not allow papers or other debris to be pulled across the fan as this will stop the necessary air flow. The TEC system will be unable to control temperature, and may become damaged.

## ***OPERATE THE TEC MODULE***

When the TEC controller shows the correct temperature, there may be a small difference between the temperature on the TEC unit and the AccuPyc display because two different sensors are being used. The AccuPyc sensor and electronics are calibrated together to compensate for any component differences between the sensor and the circuit board components. Micromeritics considers the AccuPyc temperature display to be a more accurate reflection of the sample temperature than the reading from the controller. The controller and the sensor used with the controller cannot be calibrated.

The TEC controller may be adjusted to compensate for the small difference. If the AccuPyc temperature is a little high, then reduce the setpoint of the TEC controller by the difference. Wait for stabilization. Re-adjustment may need to be repeated until the correct AccuPyc temperature is achieved.

The AccuPyc volume must be calibrated at the analysis temperature. Perform the volume calibration in the normal way until it is time to insert the reference volume (sphere or spheres). After installing the reference volume, wait at least 20 minutes to allow the reference volume to achieve the same temperature as the AccuPyc. Then continue as normal.

When it is necessary to perform AccuPyc tests at a different temperature, re-calibrate the system volume at the new temperature.

### ***VOLUME CHANGE WITH TEMPERATURE FOR THE 10 cm<sup>3</sup> ACCUPYC***

The reference spheres supplied with the 10 cm<sup>3</sup> AccuPyc are made from tungsten carbide. They were measured at 20 °C. The spheres will change volume with temperature. The change is very small and is shown in the following table. Every sphere is a slightly different size, and so the table provides the factor to be used if the value used during calibration needs to be adjusted. Multiply the volume provided with the reference spheres by the value in the right column.

<b>Temperature (°C)</b>	<b>Typical Volume (cm<sup>3</sup>), two balls</b>	<b>Factor</b>
<b>15</b>	6.37125	0.99991
<b>20</b>	6.37182	1.00000
<b>25</b>	6.37238	1.00009
<b>30</b>	6.37295	1.00018
<b>35</b>	6.37351	1.00027

For example, if the ball is 6.37182 cm<sup>3</sup> at 20 °C but run at 50 °C, multiply the Volume × the factor in the table.

$$6.37182 \text{ cm}^3 \times 1.00053 = 6.37520 \text{ cm}^3$$



## VOLUME CHANGE WITH TEMPERATURE FOR THE 100 cm<sup>3</sup> ACCUPYC

The stainless steel calibration standard (ball) supplied with the 100 cm<sup>3</sup> AccuPyc is made from 440 grade stainless steel. It was measured at 20 °C. Its volume will be higher when heated above 20 °C. The following table uses the coefficient of thermal expansion of 440 grade stainless steel (0.0000101 m/m/degree C change) to provide the volume of the sphere at various temperatures.

Every ball is a slightly different size therefore the table provides the factor to be used if the value used during calibration needs to be adjusted. Multiply the volume provided with the reference sphere by the value in the right column.

Temperature (°C)	Typical Volume (cm <sup>3</sup> )	Factor
15	51.089712	0.99995
20	51.092292	1.000000
25	51.094872	1.000051
30	51.097452	1.000101
35	51.100032	1.000152

For example, if the ball is 51.092292 cm<sup>3</sup> at 20 °C but run at 50 °C, multiply the Volume × the Factor in the table.

$$51.092292 \times 1.000303 = 51.107773$$

## ***ASPHALT DENSITY MEASUREMENT***

Samples can be analyzed in disposable cups. Any difference in the mass of the cups used for calibration and analysis will be corrected for in the reported quantities. Performing an asphalt density measurement requires disposable sample cups.

Steps 1-9 do not need to be repeated for subsequent analyses.

1. Set the instrument temperature and allow 12 hours for equilibration.
2. Go to **Options > Option Presentation**. Select *Show Cup Properties*. Verify that a checkmark displays to the left.
3. Label each disposable cup with a permanent marker and record its mass.
4. Place a disposable cup in the 3.3 cm<sup>3</sup> insert and position the insert in the sample chamber.
5. Go to **Unit [n] > Calibration > Calibrate Volume**.
  - a. Enter the mass of the cup in the *Cup mass* field.
  - b. Enter the volume of the reference sphere in the *Volume of calibration standard* field.
  - c. Select the correct chamber insert.
  - d. Select *Measured*.
  - e. Click **Start**.
6. Insert the reference sphere when prompted and resume the calibration.
7. When the calibration is complete, remove the cup and reference sphere.
8. Prepare a sample in a different disposable cup and place it in the sample chamber.
9. Create a sample file for the analysis.
10. Go to **Unit [n] > Sample Analysis** and select the sample file created in the previous step.
11. Enter the mass of the cup in the *Cup mass* field.
12. Select the chamber insert that was used for calibration.
13. Click **Start**.

## 14 TEMPERATURE-CONTROLLED ACCUPYC

---

A temperature controlled AccuPyc must be connected to a circulating bath (not provided by Micromeritics). Refer to the manufacturer operator manual for circulating bath operating instructions.

### ATTACH A CIRCULATING BATH

The rear panel of the temperature-controlled AccuPyc contains connections for a circulating bath. Provided in the accessory kit are two hose fittings and a four foot length of tubing.

1. Power off the controlling unit.
2. Remove the plugs from the **In** port and the **Out** port.

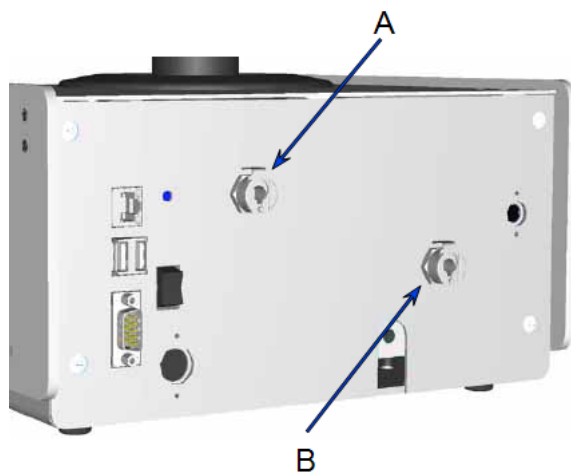

- A. Circulating bath IN port
- B. Circulating bath OUT port

3. Insert the provided hose fittings into each connector.
4. Cut the piece of 4 ft. tubing into two equal pieces of 2 feet each.
5. Install the tubing on the **In** and **Out** connectors.
6. Install the other end of the **Out** tubing to the **Inlet** connection of the bath circulator.
7. Install the other end of the **In** tubing to the **Outlet** connection of the bath circulator.
8. Set the temperature using the appropriate controls on the bath circulator.

## ADD ANALYSIS MODULES TO A TEMPERATURE CONTROLLED MODULE



If using the Windows version of the AccuPyc II, exit the application before powering off the analyzer.

1. Power OFF the controlling unit.
2. Connect the circulating bath. See [Attach a Circulating Bath on the previous page](#).
3. Connect one end of the module connector cable (provided in the analysis module accessories kit) to the connector labeled **Module Connection** on the rear panel of the control module.
4. Connect the other end of the module connector cable to the lower connector labeled **Module Connector** on the rear panel of the analysis module.

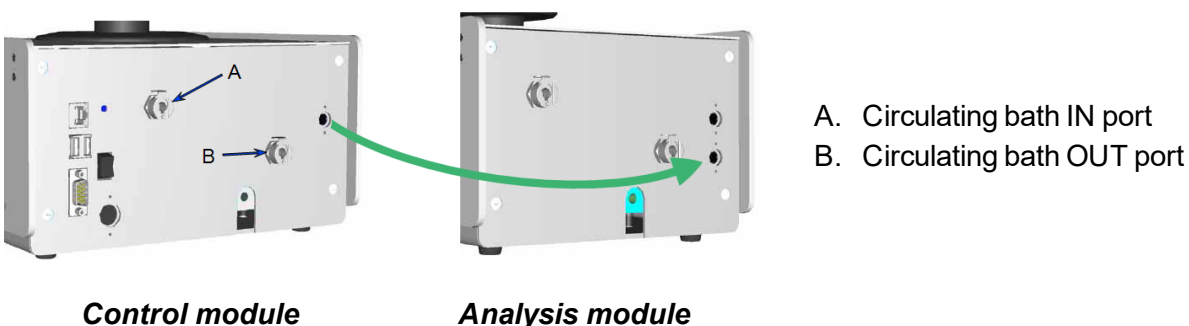

5. Power ON the analyzer. If using the Windows version of the AccuPyc II, start the application.
6. Calibrate the analysis module using the calibration kit shipped with the system. See [About Calibration on page 10 - 1](#).

## 15 MULTIVOLUME INSERT OPTION

The MultiVolume Insert option provides analysis of samples using smaller-sized sample chambers.



Wear latex gloves when handling inserts and sample cups. Oils from skin may contaminate the surface and affect analysis results. See [Handling System Components on page 11 - 5](#).

Equipment	Description
<b>AccuPyc 1 cm<sup>3</sup></b>	Includes a 0.1 cm <sup>3</sup> insert / sample cup combination.
<b>AccuPyc 10 cm<sup>3</sup></b>	Includes 1 and 3.5 cm <sup>3</sup> inserts with corresponding sample cups and appropriate calibration standards. Fritted filter lids are included for both inserts.
<b>AccuPyc 100 cm<sup>3</sup></b>	Includes 10 and 35 cm <sup>3</sup> inserts with corresponding sample cups and appropriate calibration standards. A fritted filter lid, which prevents the escape of sample particles under rapid gas flow, is included for the 10 cm <sup>3</sup> insert.
<b>AccuPyc 2000 cm<sup>3</sup></b>	Includes 650 and 1300 cm <sup>3</sup> cups, supporting inserts and calibration standards. A tool is also included to allow removal of the supporting inserts.

An insert changes the size of the sample chamber and requires its own sample cup. All inserts are shipped with appropriate cups, with the exception of the 0.1 cm<sup>3</sup> insert for the 1 cm<sup>3</sup> unit. Because of its size, the sample cup for the 0.1 cm<sup>3</sup> insert is built-in. The appearance of the inserts and cups varies.



- The fritted filter caps for the 1 cm<sup>3</sup> and 3.5 cm<sup>3</sup> inserts fit on top of the insert.
- The cap for the 10 cm<sup>3</sup> insert (shown in image) fits on the sample cup.

This example shows a 10 cm<sup>3</sup> cup and insert.

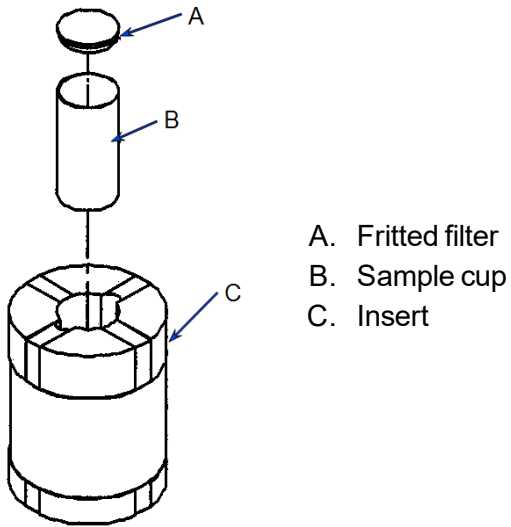

The inserts for the 2000 cm<sup>3</sup> systems are installed and removed with a special tool.

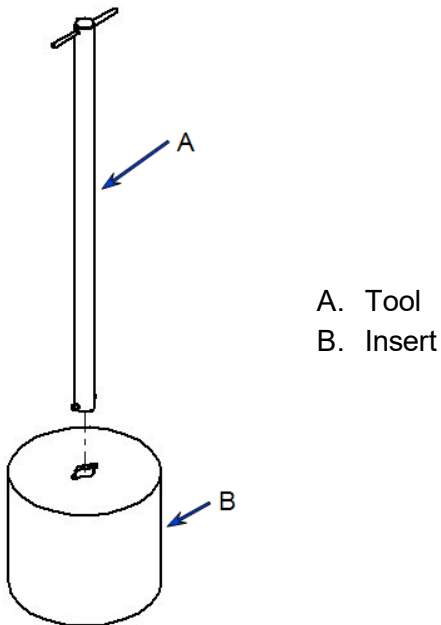

## ***INSTALL AND REMOVE INSERTS AND SAMPLE CUPS***

### ***0.1 CM<sup>3</sup> INSERT***

The MultiVolume kit contains a special tool required to install the 0.1 cm<sup>3</sup> inserts. The sample cup is built into the 0.1 cm<sup>3</sup> insert.

### ***1 CM<sup>3</sup> INSERT***

The MultiVolume kit contains a special tool required to install the 1 cm<sup>3</sup> inserts.

### **To Install the Insert**

1. Remove the sample chamber cap and place on a clean work surface with the greased side facing upward.



Contamination from airborne particles can occur rapidly. The chamber cap should be left off the sample chamber for as little time as possible.

2. Place the insert into the sample chamber.
3. Use the handling tool to grasp the cup for placement in the insert. After placing the sample into the sample cup, insert the tip of the tool into the cup and press down firmly. The handling tool features an O-ring to grip the inside surface of the sample cup.

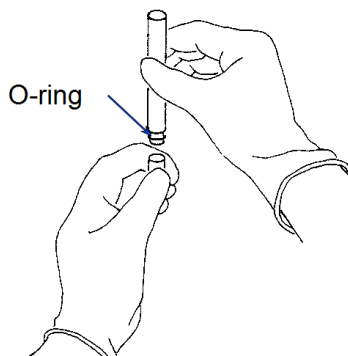

4. Place the cup into the insert, then tilt the tool to one side and remove it from the sample cup.

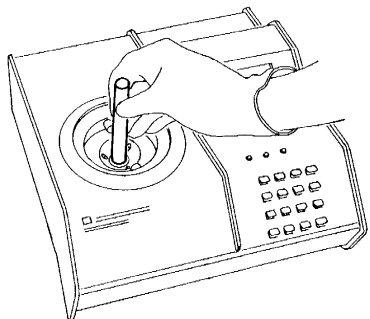

5. If using a fritted filter cap, place it onto the top of the insert.
6. Replace the sample chamber cap.

### **To Remove the Insert**

1. Remove the sample chamber cap and place on a clean work surface with the greased side facing upward.
2. Remove the fritted filter cap (if used).
3. Insert the handling tool into the sample cup until the sample cup is gripped by the O-ring.
4. Lift the sample cup out of the insert.
5. Pull the insert from the sample chamber.
6. Replace the sample chamber cap.

### **10, 3.5, AND 35 CM<sup>3</sup> INSERTS**

Remove the chamber cap and place the insert into the sample chamber. The insert should fit snugly in the chamber. Place the appropriate sample cup into the well of the insert.



Do not force the insert or cup into the openings. This may damage the instrument, insert, or sample cup.

Install the fritted filter cap (if used) before closing the sample chamber. A fritted filter cap is used to constrict gas flow and is included with some inserts. The fritted filter cap for the 10 cm<sup>3</sup> insert fits on the top of the sample cup. The fritted filter caps for the 1 and 3.5 cm<sup>3</sup> inserts fit on the top of the insert. Fritted filter caps are not available for the 0.1 and 35 cm<sup>3</sup> inserts.



## CALIBRATE INSERT

An insert must be calibrated and its operation verified. Appropriate calibration standards are included in the MultiVolume kits. For example, a 100 cm<sup>3</sup> capacity AccuPyc with a 10 cm<sup>3</sup> insert must be calibrated with the 10 cm<sup>3</sup> insert, cup, and calibration standards.

### 0.1 CM<sup>3</sup> INSERT

Because of the size of the 0.1 cm<sup>3</sup> insert, its calibration is performed in a different manner from that of other inserts.



If the 1 cm<sup>3</sup> pycnometer has not been calibrated recently, perform a calibration before calibrating the 0.1 cm<sup>3</sup> insert.

1. Remove the sample chamber cap and place on a clean work surface with the greased side facing upward.
  2. Place the insert into the sample chamber (the sample cup is built into the insert). Replace the chamber cap.
  3. Press **Alt + 4** to access the *Analyze* function. Press **ENTER** until the *Chamber Insert* prompt is displayed. Ensure that *None* is displayed.
  4. Press **ENTER** to display the *Analyze* prompt. Press **ENTER** to begin the calibration.
  5. After the calibration is complete, the *Reload* prompt is displayed.
  6. Press **CHOICE** until the average measured volume is displayed. Record this value.
  7. Press **Alt + 2** to access *Setup*.
  8. Press **CHOICE** until *Calibration Data* is displayed.
  9. Press **ENTER** to display the *Chamber Insert* prompt.
  10. Ensure that *None* is selected, then press **ENTER** to display the *Cell Volume* prompt.
  11. Subtract the average volume of the 0.1 cm<sup>3</sup> insert / cup (recorded in Step 6) from the cell volume displayed in the prompt. Record this value.
  12. Press **ENTER** to display the *Expansion Volume* prompt.
  13. Record the value displayed for the expansion volume, then press **ENTER** to return to the *Calibration Data* prompt.
  14. Press **ENTER**. The *Chamber Insert* prompt is displayed.
  15. Press **CHOICE** until 0.1 cm<sup>3</sup> is displayed, then press **ENTER** to display the *Cell Volume* prompt. Enter the value recorded in Step 11.
  16. Press **ENTER** to display the *Expansion Volume* prompt. Enter the value recorded in Step 12.
  17. Press **SAVE** to save the information and return to the *Reload* prompt.
- The pycnometer is now ready for analyses using the 0.1 cm<sup>3</sup> insert / cup.

## 1, 10, 3.5, 35, 650, AND 1300 CM<sup>3</sup> INSERTS

1. Remove the sample chamber cap and place on a clean work surface with the greased side facing upward.
2. Place the insert and sample cup into the sample chamber. Replace the chamber cap.
3. Calibrate the insert. See [About Calibration on page 10 - 1](#).
4. See [Verify Operation on page 10 - 11](#).

## OPERATING PARAMETERS USING THE KEYPAD

To operate using inserts, access the *Chamber Insert* prompt to select the appropriate MultiVolume insert.

1. Press **Alt + 2** to access the *Setup* function.
2. Press **CHOICE** until *Report Options* is displayed, then press **ENTER**.
3. Continue pressing **ENTER** until the *Request Insert* prompt is displayed.
4. Press **CHOICE** until *Yes* is displayed, then press **ENTER**.

Unit[n]	SN1234	10 cm <sup>3</sup>
Report Options		
Request insert?		
Yes		

5. Press **SAVE** to save the changes and return to the *Reload* prompt.

A *Chamber Insert* prompt will display during all normal operating procedures. For example, a *Chamber Insert* prompt will display when starting a calibration or analysis.

## 16 MULTIGAS OPTION

The Multigas option enables the AccuPyc to use up to four different gases. The Multigas assembly consists of:

- Valve assembly and two retaining screws
- Gas entrance tubing for connection from the analyzer to the valve assembly
- Gas supply tubing for four gases

### INSTALL THE MULTIGAS ASSEMBLY

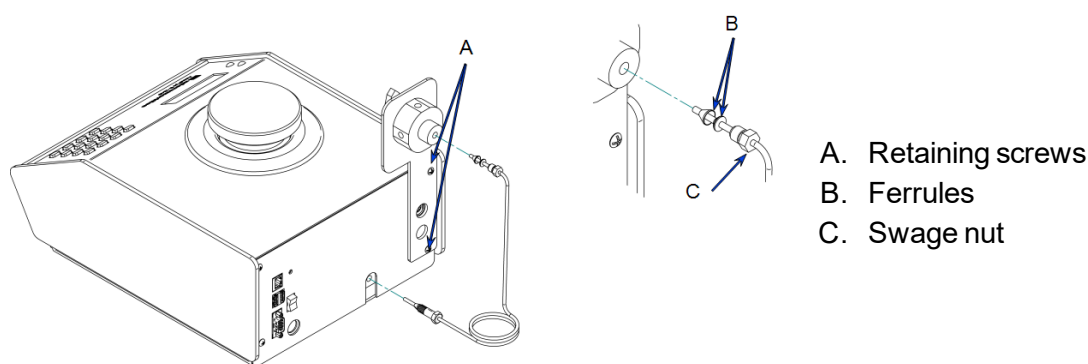

If a gas is attached to the gas inlet on the rear panel of the analyzer, close the gas cylinder valve and remove the inlet tubing from the analyzer before installing the multigas assembly. The gas can then be attached to one of the inlet valves on the assembly.

1. Remove the two retaining screws on the rear panel of the AccuPyc.
2. Position the valve assembly against the rear panel so that the retaining screw holes on the valve assembly align with those on the rear panel of the analyzer.
3. Attach the valve assembly to the rear panel using the two screws included in the multigas kit.
4. Carefully cut and remove the cable ties holding the gas entrance tubing in position and remove the ties.
5. Remove the protective caps from the ends of the gas entrance tubing, then remove the ferrules from the upper end of the tubing.
6. Remove the nut from the center port and slide it onto the end of the gas entrance tubing, then replace the front and rear ferrules.
7. Insert the tubing into the center port of the multigas assembly. Use the nut to secure the tubing to the assembly.
8. Insert the other end of the tubing into the gas inlet. Use the self contained swage nut to secure the tubing to the inlet.

## CONNECT GASES

1. Connect one end of the gas supply tubing to the gas supply.
2. Insert the other end of the tubing into one of the valve inlets on the multigas assembly.
3. The faceplate of the valve assembly contains four sections; one for each gas inlet on the assembly. Write the name of the gas in the applicable section.

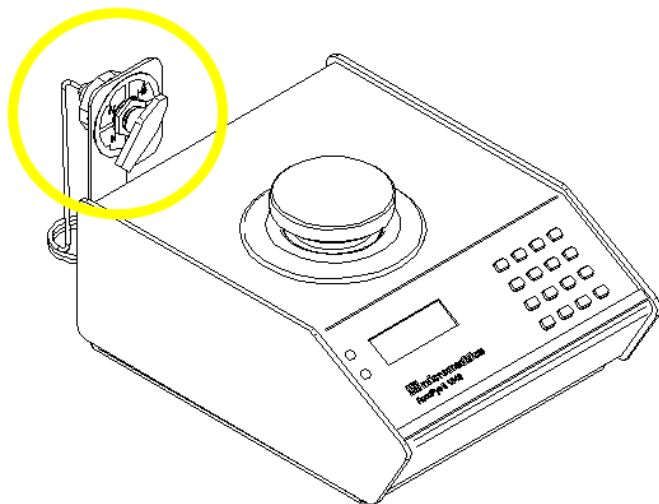

*Write the name of the gas connected to the inlet*

## SELECT GASES

After installing the gases, use the knob to select the gas. Purge the gas lines when changing gases.

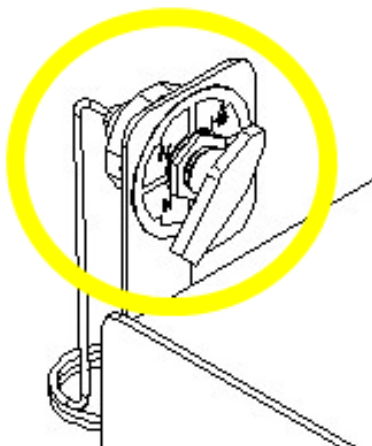

*Turn the knob to select the gas*

## A ADVANCED REPORTS - PYTHON MODULE

---

### CFR Note

In a 21CFR11 environment, the Advanced reports feature is applicable to members of the Developer group only.

- [Enable the Use of Overlay Data on page A - 11](#)
- [MicModule Python Calls on page A - 13](#)
- [Python Reports on page A - 8](#)
- [Scripts on page A - 6](#)

The mic Python module is automatically imported when running a user supplied script. The module provides access to primary and overlay data and provides support for summary, tabular, and graphical reports.

- **Summary reports.** Consist of summary sections, each containing a two-column table of label and value pairs. Summary reports are created with the *mic.summary* call.
- **Tabular reports.** Consist of one or more tables each containing one or more labeled columns of data. Tabular reports are created with the *mic.table* call.
- **Graphical reports.** Consist of a single graph with one or more curves on one or two y-axes. Graphical reports are created with the *mic.graph* call.

Calls for accessing the sample file data can be found in the *Mic Module Python Calls* section of this appendix. More advanced example python scripts are included in the analyzer software. Application specific discussions can be found on <https://www.micromeritics.com/Pressroom/MicroReport.aspx>



The examples in this topic are also included as a part of the Micromeritics installation process and are located in the *Scripts* sub-directory.

## ADVANCED REPORT OPTIONS



AccuPyc 1345 specific example scripts are located in the scripts directory which document the usage of 1345 related python calls.

Up to five Advanced reports, each with up to 10 summary reports, 10 tabular reports, and 10 graphical reports can be created. To use this feature, a file containing a Python script that imports a "mic" Python module must be created. See [MicModule Python Calls on page A - 13](#) for an example of Python script and functions for the "mic" Python module.

1. Create the Python script and save it in the *Scripts* directory.
2. Open a sample file with a *Complete* status.
3. Select *Advanced* in the view selector drop-down list at the bottom of the window to return to the tabbed view.
4. On the *Report Options* tab, select *Advanced Reports* in the *Selected Reports* list box, then click **Edit**.
5. On the *Advanced Report Options* window, click **Add** in the *Available Scripts* group box to locate and select the Python script. Repeat for each script to be added.

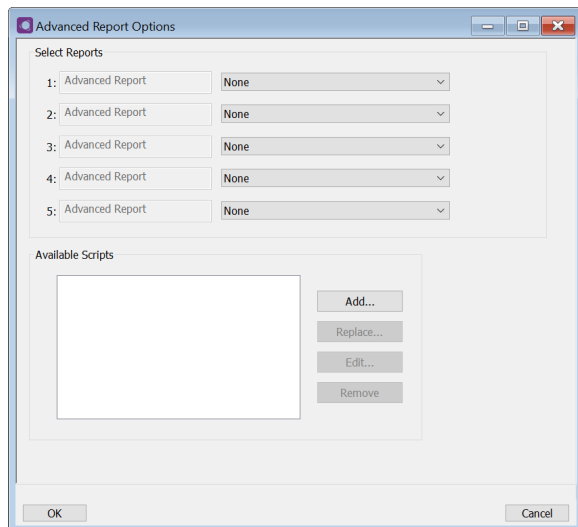

6. In the *Selected Reports* group box, click the drop-down arrows to select up to five Python scripts previously added in the *Available Scripts* box.
7. On the *Report Options* tab, click **Preview**. The Python Reports will be included on the tabs across the top portion of the *Reports* window.

## Advanced Reports

Field or Button	Description
<b>Advanced Report 1 through 5</b> [drop-down box]	Use the drop-down lists to select currently-defined functions used to define the report calculations and output.
<b>Available Scripts</b> [group box]	Lists the available reports and provides the option to add, replace, edit, or remove reports.
 For fields and buttons not listed in this table, see <a href="#">Common Fields and Buttons on page 3 - 2</a> .	

## GRAPHIC REPORTS

- [Python Reports on page A - 8](#)

### ADD A CURVE

This script adds a curve to the last created graphical report:

```
mic.graph.add(name, x, y, yyaxis=False, color=None, linestyle='-',
              marker='a', graphtype='both', interpolation='akima');
```

Keyword arguments:

```
name      --- the curve name
x         --- list of x values; must be a list of floats
           (or convertible) and the same length as y
y         --- list of y values; must be a list of floats
           (or convertible) and the same length as x
yyaxis    --- place this curve on the yy-axis if True
           otherwise place on the y-axis (default = False)
color     --- RGB color as an HTML hex string (e.g., '#4169e1')
           or a three-element list or tuple (e.g., [65,105,225]);
           if None, color is automatically selected (default = None)
linestyle --- line style; (default = '-')
           '-'      : solid
           '--'     : dash
           '.'      : dot
           '-.'     : dash dot
           '-..'    : dash dot dot
marker    --- marker shape; (default = 'a')
           '+'      : plus
```

```

'o' or '0' : circle
'x'       : cross
'^'       : up triangle
'v'       : down triangle
's'       : square
'd'       : diamond
'8'       : hourglass
'~'       : horizontal hourglass
'' or None : no marker
'a'       : automatically selected
graphtype --- graph type; (default = 'both')
'curve' or 'c' : curve
'points' or 'p' : points
'both' or 'b' : curve-and-points
'hist' or 'h' : histogram
interpolation -- linear or akima spline interpolation (default='akima')
'akima' use akima spline
'linear' use linear interpolation

```

## ***ADD A CURVE USING THE SECOND Y-AXIS***

This script adds a curve to the last created graphical report using the second y-axis:

```
mic.graph.addyy(name, xx, yy):
```

Add a curve to the last created graphical report using the second y-axis. The arguments to this call are the same as to mic.graph.add.

## ***CREATE A NEW GRAPHICAL REPORT***

```
mic.graph(title='User Graph', xlabel='X axis', ylabel='Y axis', ylabel='YY
axis',
          xlinear=True, ylinear=True, ylinear=True,
          xinvert=False, yinvert=False, yyinvert=False,
          xrange=None, yrange=None, yrange=None,
          xbars_id=''):

```

Keyword arguments:

```

title    --- the graphical report title (default = 'User Graph')
xlabel   --- x-axis label (default = 'X axis')
ylabel   --- y-axis label (default = 'Y axis')
ylabel   --- yy-axis label (default = 'YY axis')
xlinear  --- x-axis linear scale; if false, use log scale
          (default = True)
ylinear  --- y-axis linear scale; if false, use log scale
          (default = True)
ylinear  --- yy-axis linear scale; if false, use log scale

```



```
(default = True)
xinvert  --- Invert x-axis if true (default = False)
yinvert  --- Invert y-axis if true (default = False)
yyinvert --- Invert yy-axis if true (default = False)
xrange   --- None, or two values giving the min and max
          range of the axis.
yrange   --- None, or two values giving the min and max
          range of the axis.
yyrange  --- None, or two values giving the min and max
          range of the axis.
xbars_id --- None, or the id of an xbar control created
          via the mic.control() object
```

## SCRIPTS

### ***RUN A SCRIPT***

1. Open a sample file with a *Complete* file status.
2. Select *Advanced* in the view selector drop-down list at the bottom of the window.
3. Select the *Report Options* tab.
4. Highlight *Advanced* in the *Reports* list box, then click **Edit**.
5. On the *Advanced Report Options* window, click **Add**. Locate and select one or more python scripts then click **Select**. The selected scripts become a part of the drop-down list in the *Available Scripts* section of the *Advanced Report Options* window.
6. In the *Selected Reports* section, select up to five Advanced reports in the drop-down lists. Use the **Pressures** button to include or exclude available pressures in the report.
7. Click **OK**.
8. Click **Preview** on the *Report Options* tab to view all reports selected in the previous window.

### ***REMOVE A SCRIPT***

Select the script in the *Available Scripts* box then click **Remove**. The script is removed from the application however, the original .py text file is not affected.

## EDIT A SCRIPT



When a script is added, the code is stored within the application. If the script changes outside of the application, the script file will have to be re-added to the Advanced Report Options window for the changes to take affect.

Field or Button	Description
<b>Add</b> [ <i>button</i> ]	Adds one or more scripts to the <i>Available Scripts</i> box. The added scripts then become available as options in the <i>Selected Reports</i> section.
<b>Edit</b> [ <i>button</i> ]	Edits the script stored within the application but does not affect the original .py text file.
<b>Remove</b> [ <i>button</i> ]	Removes the script from the <i>Available Scripts</i> box but does not affect original .py text file.
<b>Replace</b> [ <i>button</i> ]	Replaces the contents of the selected script however, the script name remains the same.

## PYTHON REPORTS

### GRAPHIC REPORT

This script is an example of the mic module producing a graph with two curves:

```
import mic
import numpy as np

mic.graph( 'My Graph', 'X', 'F(X)' )
myx = np.array( [0.1, 0.2, 0.3, 0.4, 0.5, 0.6, 0.7, 0.8, 0.9, 1.0 ] )
mic.graph.add( 'x2', myx, myx*myx, marker='o' )
mic.graph.add( 'sin(X)', myx, np.sin(myx), marker='^' )
```

The results are:

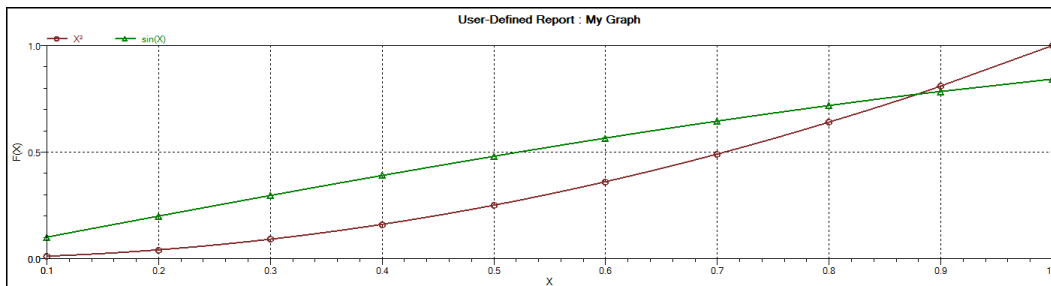

## **SUMMARY REPORT**

This script produces a summary report with two summaries:

```
import mic

mic.summary( "My Summaries" )
mic.summary.add( "Summary A",
                ["Label 1:", "Label 2:", "Label 3:"],
                ["val1", "val2", "val3"] )
mic.summary.add( "Summary B",
                ["Label 4:", "Label 5:", "Label 6:"],
                ["val4", "val5", "val6"] )
```

The result is:

### **Summary A**

Label 1: val1  
Label 2: val2  
Label 3: val3

### **Summary B**

Label 4: val4  
Label 5: val5  
Label 6: val6

## TABULAR REPORT

If more than one column is required, the call *mic.table* is employed. This script produces a tabular report consisting of two tables.



This script uses the Python package "numpy" and c-style formatting of the numerical values.

```
import mic
import numpy as np

mic.table( "My Tables" )
mic.table.addtable( "My Set A" )
mic.table.addcolumn( "X", ["1.0", "2.0", "3.0"] )
mic.table.addcolumn( "Y", ["0.5", "1.0", "1.5"] )
x1 = 0.2
x2 = 0.5
x3 = 3.14159/2
mic.table.addtable( "My Set B" )
mic.table.addcolumn( "X", ['{:8.3f}'.format(x1),
                           '{:8.3f}'.format(x2),
                           '{:8.3f}'.format(x3)] )
mic.table.addcolumn( "sin(X)", ['{:8.3f}'.format(np.sin(x1)),
                                '{:8.3f}'.format(np.sin(x2)),
                                '{:8.3f}'.format(np.sin(x3))] )
mic.table.addcolumn( "cos(X)", ['{:8.3f}'.format(np.cos(x1)),
                                '{:8.3f}'.format(np.cos(x2)),
                                '{:8.3f}'.format(np.cos(x3))] )
```

The result is:

<b>My Set A</b>		
X	Y	
1.0	0.5	
2.0	1.0	
3.0	1.5	

<b>My Set B</b>		
X	sin(X)	cos(X)
0.200	0.199	0.980
0.500	0.479	0.878
1.571	1.000	0.000

## ENABLE THE USE OF OVERLAY DATA

1. On the *Report Options* tab, click **Overlays**.
2. On the *Plot Overlay Sample Selection* window, to move a file from the *Available Files* list box to the *Selected Files* list box, either double click a file name in the *Available Files* list box or click one or more files in the *Available Files* list box then click **Add**.

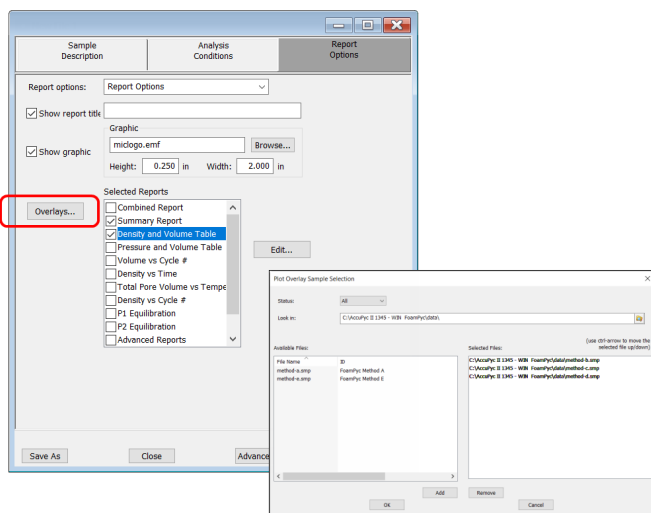

3. Click **OK**.
4. On the *Report Options* tab, highlight *Advanced* in the *Selected Reports* list box.
5. Click **Edit** to the left of the *Selected Reports* list box.
6. Select the *Overlay samples* checkbox to the right of the selected report.
7. Click **OK**.
8. Run the script using the instructions found in [Scripts on page A - 6](#).

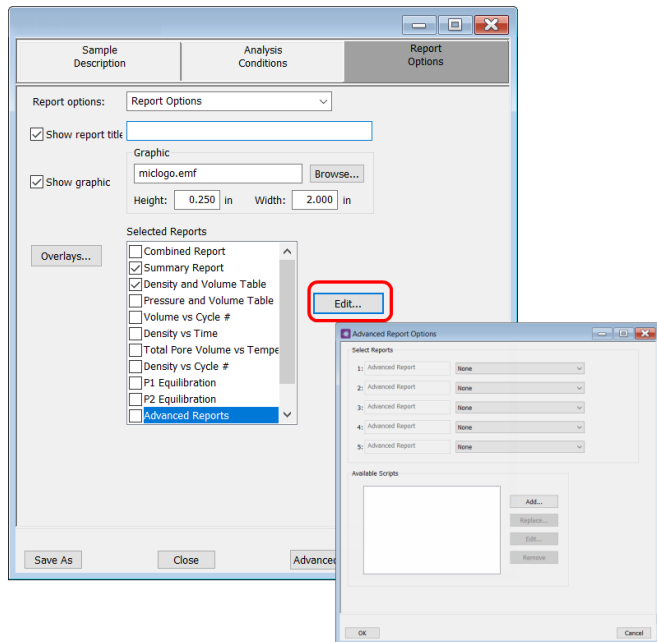



## ***MICMODULE PYTHON CALLS***

### ***TABLES***

Available Mic Python calls for tables:

- Create a new tabular report
- Add a column
- Add a table

#### **Add a Table**

This script adds a table to the last created tabular report:

```
mic.table.addtable( name )
```

Keyword arguments:

```
name --- the table name
```

#### **Add a Column**

This script adds a column to the last created table:

```
mic.table.addcolumn(header, values, align='r'):
```

Keyword arguments:

```
header --- column header; must be a string (or convertible)
values --- column values; must be a list of strings (or convertible)
align --- column alignment; 'r', 'l', 'c' for right, left, and center justified
```

#### **Create a New Tabular Report**

```
mic.table( title='User Table' )
```

Keyword arguments:

```
title --- the tabular report title (default = 'User Table')
```

---

## ***SUMMARY REPORTS***

- [\*Python Reports on page A - 8\*](#)

### **Add a Summary Section**

This script adds a summary section to the last created summary report:

```
mic.summary.add( name, labels, values )
```

Keyword arguments:

```
name    --- summary section name
labels  --- column of labels; must be a list of strings
         (or convertible) and the same length as values
values  --- column of values; must be a list of strings
         (or convertible) and the same length as labels
```

### **Create a New Summary Report**

```
mic.summary( title='User Summary' )
```

Keyword arguments:

```
title  --- the summary title
```

## GRAPHIC REPORTS

- [Python Reports on page A - 8](#)

### Add a Curve

This script adds a curve to the last created graphical report:

```
mic.graph.add(name, x, y, yyaxis=False, color=None, linestyle='-',
              marker='a', graphtype='both', interpolation='akima');
```

Keyword arguments:

```
name      --- the curve name
x         --- list of x values; must be a list of floats
           (or convertible) and the same length as y
y         --- list of y values; must be a list of floats
           (or convertible) and the same length as x
yyaxis    --- place this curve on the yy-axis if True
           otherwise place on the y-axis (default = False)
color     --- RGB color as an HTML hex string (e.g., '#4169e1')
           or a three-element list or tuple (e.g., [65,105,225]);
           if None, color is automatically selected (default = None)
linestyle --- line style; (default = '-')
           '-'      : solid
           '--'     : dash
           '.'      : dot
           '-.'     : dash dot
           '-..'    : dash dot dot
marker    --- marker shape; (default = 'a')
           '+'      : plus
           'o' or '0' : circle
           'x'      : cross
           '^'      : up triangle
           'v'      : down triangle
           's'      : square
           'd'      : diamond
           '8'      : hourglass
           '~'      : horizontal hourglass
           '' or None : no marker
           'a'      : automatically selected
graphtype --- graph type; (default = 'both')
           'curve' or 'c' : curve
           'points' or 'p' : points
           'both' or 'b' : curve-and-points
```

```

        'hist'    or 'h' : histogram
interpolation -- linear or akima spline interpolation (default='akima')
                'akima' use akima spline
                'linear' use linear interpolation

```

## **Add a Curve Using the Second Y-Axis**

This script adds a curve to the last created graphical report using the second y-axis:

```
mic.graph.addyy(name, xx, yy):
```

Add a curve to the last created graphical report using the second y-axis. The arguments to this call are the same as to mic.graph.add.

## **Create a New Graphical Report**

```
mic.graph(title='User Graph', xlabel='X axis', ylabel='Y axis', ylabel='YY
axis',
          xlinear=True, ylinear=True, yylinear=True,
          xinvert=False, yinvert=False, yyinvert=False,
          xrange=None, yrange=None, yyrange=None,
          xbars_id=''):

```

Keyword arguments:

```

title    --- the graphical report title (default = 'User Graph')
xlabel   --- x-axis label (default = 'X axis')
ylabel   --- y-axis label (default = 'Y axis')
ylabel   --- yy-axis label (default = 'YY axis')
xlinear  --- x-axis linear scale; if false, use log scale
          (default = True)
ylinear  --- y-axis linear scale; if false, use log scale
          (default = True)
yylinear --- yy-axis linear scale; if false, use log scale
          (default = True)
xinvert  --- Invert x-axis if true (default = False)
yinvert  --- Invert y-axis if true (default = False)
yyinvert --- Invert yy-axis if true (default = False)
xrange   --- None, or two values giving the min and max
          range of the axis.
yrange   --- None, or two values giving the min and max
          range of the axis.
yyrange  --- None, or two values giving the min and max
          range of the axis.
xbars_id --- None, or the id of an xbar control created
          via the mic.control() object

```

## GET SAMPLE INFORMATION ITEM

```
mic.sample_information( item, sample_number = 0 )
```

Keyword arguments:

```
item          --- string identifying the item to be returned.
                  Accepted identifiers are

                  'sample mass'
                  'sample description'
                  'analysis temperature' (degrees Kelvin)
                  'sample density'      ( g/cm3 )

sample_number --- Sample to retrieve (default = 0).
0              : the current sample file
1 through 8   : the corresponding overlay sample file
```

Usage:

```
mass = sample_information('sample mass')
mass = sample_information('sample mass',0)
```

**Blank Page**

---

## B EXPORTED DATA EXAMPLE

---

### Sample Information

Sample Information  
Method: Default  
Sample: Pt-Alumina  
Operator: ELV  
Submitter:  
Mass type: Entered  
Sample mass: 6.3067 g  
Density: 1.000 g/cm<sup>3</sup>  
Type of data: Automatically collected  
Instrument type: 1345  
Original instrument type: 1345  
Comments: 004/16825/00  
Lot SE13378-4

Sample Cup Properties  
Description: Sample Cup Properties  
Cup mass: 0.0000 g  
Cup density: 2.7000 g/cm<sup>3</sup>

Material Properties  
Envelope density: 1.0000 g/cm<sup>3</sup>  
Liquid density: 1.0000 g/cm<sup>3</sup>  
Solids density: 1.0000 g/cm<sup>3</sup>

### Analysis Conditions

Analysis conditions:  
Description: Analysis Conditions  
Analysis gas: Helium  
Number of purges: 10  
Purge fill pressure: 19.500 psig  
Number of cycles: 10  
Cycle fill pressure: 19.500  
Equilib. rate: 0.0050 psig/min  
Use run precision? No  
Analysis method: Standard  
Record P1 equilibration data? No  
Record P2 equilibration data? No

## Report Options

Description: Report Options

Show report title: Yes

Show graphic: Yes

Graphic height: 0.250 in

Graphic width: 2.000 in

Overlay: None

### Reports

Combined Report No

Summary Report Yes

Density and Volume Table Yes

Pressure and Volume Table No

Volume vs Cycle # Yes

Density vs Time No

Total Pore Volume vs Temperature No

Density vs Cycle # Yes

P1 Equilibration No

P2 Equilibration No

Advanced Reports No

Options Report No

Sample Log No

### Summary Report

Sample Volume

Average: Yes

Standard Deviation: Yes

Coefficient of Variation: No

Pass/Fail: No

Sample Density

Average: Yes



## Summary Report

Standard Deviation: Yes  
Coefficient of Variation: No  
Pass/Fail: No  
Specific Gravity  
Average: No  
Standard Deviation: No  
Coefficient of Variation: No  
Pass/Fail: No  
Total Pore Volume\*  
Average: No  
Standard Deviation: No  
Coefficient of Variation: No  
Pass/Fail: No  
Total Solids Concentration  
Average: No  
Standard Deviation: No  
Coefficient of Variation: No  
Pass/Fail: No  
Percent Porosity\*  
Average: No  
Standard Deviation: No  
Coefficient of Variation: No  
Pass/Fail: No  
Temperature  
Average: No  
Standard Deviation: No  
Coefficient of Variation: No  
Pass/Fail: No

## Density and Volume Table

Column 1 Cycle Number  
Column 2 Volume  
Column 3 Volume Deviation  
Column 4 Density  
Column 5 Density Deviation  
Column 6 Elapsed Time  
Column 7 Temperature

Density and Volume Table

- Column 1 Cycle Number
- Column 2 Volume
- Column 3 Volume Deviation
- Column 4 Density
- Column 5 Density Deviation
- Column 6 Elapsed Time
- Column 7 Temperature

Summary Data

Volume:  
Average: Yes  
Standard Deviation: Yes  
Coefficient of Variation: No

Density:  
Average: Yes  
Standard Deviation: Yes  
Coefficient of Variation: No

Specific Gravity:  
Average: No  
Standard Deviation: No  
Coefficient of Variation: No

Total Pore Volume\*:  
Average: No  
Standard Deviation: No  
Coefficient of Variation: No

Total Solids Concentration:  
Average: No  
Standard Deviation: No  
Coefficient of Variation: No

Percent Porosity\*:  
Average: No  
Standard Deviation: No  
Coefficient of Variation: No

Temperature:

## Summary Data

Average: No  
Standard Deviation: No  
Coefficient of Variation: No

Volume (60° F):  
Average: No  
Standard Deviation: No  
Coefficient of Variation: No

Density (60° F):  
Average: No  
Standard Deviation: No  
Coefficient of Variation: No

Specific Gravity (60° F):  
Average: No  
Standard Deviation: No  
Coefficient of Variation: No

## Volume vs Cycle #

X Axis: Cycle Number  
Y Axis: Volume  
Overlay: Overlay Samples  
Show Average: Yes  
Show Reference: No  
Reference Value: 0.0000 cm<sup>3</sup>  
Show +/-: No  
+/- Value: 3.0 sigma  
Show Range: No  
Minimum: 0.0000 cm<sup>3</sup>  
Maximum: 0.0000 cm<sup>3</sup>  
Plot Curve: Yes  
Plot Points: Yes  
Autoscale X Axis: Yes  
Autoscale Y Axis: Yes

## Density vs Cycle #

X Axis: Cycle Number  
Y Axis: Density  
Overlay: Overlay Samples  
Show Average: Yes  
Show Reference: No  
Reference Value: 0.0000 g/cm<sup>3</sup>  
Show +/-: No  
+/- Value: 3.0 sigma  
Show Range: No  
Minimum: 0.0000 g/cm<sup>3</sup>  
Maximum: 0.0000 g/cm<sup>3</sup>  
Plot Curve: Yes  
Plot Points: Yes  
Autoscale X Axis: Yes  
Autoscale Y Axis: Yes

Collected Data

Chamber Insert: None  
 Cell Volume: 11.743300 cm<sup>3</sup>  
 Expansion Volume: 8.410800 cm<sup>3</sup>

Collected Data				
Elapsed Time (mm:ss)	P1 Pressure (psig)	P2 Pressure (psig)	Volume (cm <sup>3</sup> )	Temperature (°C)
9:28	19.540010	10.525300	1.923108	24.898489
11:55	19.528679	10.519403	1.922688	24.857891
14:20	19.538498	10.524772	1.922529	24.920292
16:48	19.540857	10.526293	1.922023	24.972166
19:18	19.536482	10.524108	1.921674	24.965399
21:47	19.528141	10.519802	1.921295	25.047722
24:19	19.540800	10.526590	1.921358	25.095461
26:52	19.532545	10.522022	1.921604	25.132675
29:14	19.541279	10.527058	1.920935	25.145832
31:44	19.541832	10.527386	1.920874	25.202969

Sample Log

Sample Log		
Date	Time	Log Message
9/17/2019	9:45:46 AM	Analysis done.

## C SAMPLE VOLUME EQUATION DERIVATION

### 10, 100, AND 350 CM<sup>3</sup> UNITS

The AccuPyc II is a gas displacement pycnometer which measures the volume of solid objects of irregular or regular shape whether powdered or in one piece. A greatly simplified diagram of the instrument is shown below.

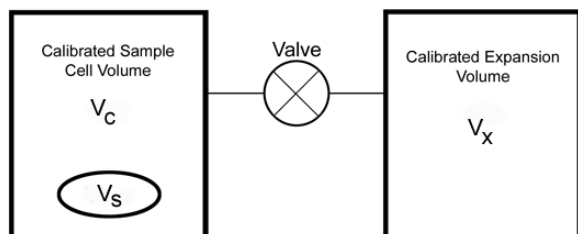

Sample volume is determined from the known cell and expansion volumes and from measured pressures.

The cell and expansion chamber are initially at ambient pressure and the valve is closed. The cell is then charged to an elevated pressure.

The ideal gas law gives:

$$P_1(V_c - V_s) = n_c RT \quad (1)$$

where

$n_c$	=	moles of gas in the sample cell
$R$	=	the gas constant
$T$	=	temperature
$V_c$	=	cell volume
$V_s$	=	sample volume
$V_x$	=	expansion volume
$P_1$	=	initial cell pressure

Expansion volume:

$$P_a V_x = n_x RT \quad (2)$$

where

$$\begin{aligned}
 P_a &= \text{ambient pressure} \\
 n_x &= \text{moles of gas in the expansion volume}
 \end{aligned}$$

When the valve is opened, the pressure falls to an intermediate value,  $P_2$ , and mass balance yields:

$$P_2(V_c - V_s + V_x) = n_c RT + n_x RT \quad (3)$$

Substituting from equations (1) and (2) into (3):

$$P_2(V_c - V_s + V_x) = P_1(V_c - V_s) + P_a V_x \quad (4)$$

or

$$(P_2 - P_1)(V_c - V_s) = (P_a - P_2)V_x \quad (5)$$

then

$$V_c - V_s = \frac{P_a - P_2}{P_2 - P_1} V_x \quad (6)$$

Adding and subtracting  $P_a$  in the denominator and rearranging gives

$$-V_s = -V_c + \frac{P_a - P_2}{P_2 - P_a - P_1 + P_a} V_x \quad (7)$$

Dividing by  $(P_a - P_2)$  in both the numerator and denominator

$$V_s = V_c - \frac{V_x}{-1 - \left(\frac{P_1 - P_a}{P_a - P_2}\right)} \quad (8)$$

or

$$V_s = V_c - \frac{V_x}{\left(\frac{P_1 - P_a}{P_2 - P_a}\right) - 1} \quad (9)$$

Using gauge pressure defined as:

$$P_{ig} = P_i - P_a \quad (10)$$

equation (9) is rewritten as:

$$V_s = V_c - \frac{V_x}{\frac{P_{1g}}{P_{2g}} - 1} \quad (11)$$

## **1 CM<sup>3</sup> AND 2000 CM<sup>3</sup> UNITS**

The 1 cm<sup>3</sup> and 2000 cm<sup>3</sup> pycnometers operate by filling the expansion chamber while the sample cell remains at ambient pressure. After  $P_1$  is equilibrated, the expansion valve opens to allow gas to expand into the sample chamber and  $P_2$  is equilibrated.

For the 1 cm<sup>3</sup> and 2000 cm<sup>3</sup> pycnometers, equation (1) becomes

$$P_1 V_x = n_x RT$$

and equation (2) becomes

$$P_a (V_c - V_s) = n_c RT$$

A derivation similar to that above yields the working equation for the 1 cm<sup>3</sup> and 2000 cm<sup>3</sup> pycnometers

$$V_s = V_c - V_x \left( \frac{P_{1g}}{P_{2g}} - 1 \right)$$

**Blank Page**

---



## D TRANSMITTED DATA

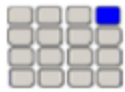

Use these instructions for keypad installations only. If a computer is attached to the module, skip this section. All setup functions will be done in the analysis software.

Analysis and calibration data can be transmitted in a single column or spreadsheet with data in ASCII delimited format. Units are displayed as:

### Data Units

Type	Measurement
Date	DD/MM/YY
Time	HH:MM:SS
Pressure	psig
Temperature	°C
Elapsed Time	seconds

## ANALYSIS REPORT

### Analysis Report - Spreadsheet

Record Number	Description	Form
1	Version Number	20 characters
2	Serial Number	1 integer
3	Report type = analysis	8 characters
4	Start (reported on one line as ASCII comma delimited data) <ul style="list-style-type: none"> <li>■ 4a. Date</li> <li>■ 4b. Time</li> </ul>	8 characters (each)
5	Stop (reported on one line as ASCII comma delimited data) <ul style="list-style-type: none"> <li>■ 5a. Date</li> <li>■ 5b. Time</li> </ul>	8 characters (each)
6	Temperature	1 floating point

## Analysis Report - Spreadsheet (continued)

Record Number	Description	Form
7	Description line 1	20 characters
8	Description line 2	20 characters
9	Sample IDs	20 characters
10	Sample mass	1 floating point
11	Number of purges	1 integer
12	Equilibration rate	1 floating point
13	Chamber Insert: <ul style="list-style-type: none"> <li>■ 0 = None</li> <li>■ 1 = 10 cm<sup>3</sup> (100 cm<sup>3</sup> unit)               <ul style="list-style-type: none"> <li>1 cm<sup>3</sup> (10 cm<sup>3</sup> unit)</li> <li>0.1 cm<sup>3</sup> (1 cm<sup>3</sup> unit)</li> </ul> </li> <li>■ 2 = 35 cm<sup>3</sup> (100 cm<sup>3</sup> unit)               <ul style="list-style-type: none"> <li>3.5 cm<sup>3</sup> (10 cm<sup>3</sup> unit)</li> </ul> </li> </ul>	1 integer
14	Cell volume	1 floating point
15	Expansion volume	1 floating point
16	Average volume	1 floating point
17	Volume standard deviation	1 floating point
18	Average density	1 floating point
19	Density standard deviation	1 floating point
20	Number of runs	1 integer
21	Run precision <ul style="list-style-type: none"> <li>■ 0 = Disabled</li> <li>■ 1 = Enabled</li> </ul>	1 floating point
22	Percent full scale	1 floating point
23	Carriage return / Line feed	
24	Carriage return / Line feed	

**Analysis Report - Spreadsheet (continued)**

<b>Record Number</b>	<b>Description</b>	<b>Form</b>
<b>25</b>	Carriage return / Line feed	
<b>26</b>	Run number and pressure (reported on one line as ASCII comma delimited data)	
<b>26a</b>	Run number	1 integer
<b>26b</b>	P1	1 floating point
<b>26c</b>	P2	1 floating point
<b>26d</b>	Include in average calculation <ul style="list-style-type: none"> <li>■ 0 = Excluded</li> <li>■ 1 = Included</li> </ul>	1 integer
<b>26e</b>	Elapsed time	1 unsigned integer
<b>26f</b>	Volume	1 floating point
<b>26g</b>	Volume deviation	1 floating point
<b>26h</b>	Density	1 floating point
<b>26i</b>	Density deviation	1 floating point
<b>27</b>	Temperature (all temperature data)	1 floating point

## CALIBRATION REPORT

### Calibration Report - Single Column

Record Number	Description	Form
1	Version Number	20 characters
2	Serial Number	1 integer
3	Report type = calibration	11 characters
4	Start (reported on one line as ASCII comma delimited data) <ul style="list-style-type: none"> <li>■ 4a. Date</li> <li>■ 4b. Time</li> </ul>	8 characters (each)
5	Stop (reported on one line as ASCII comma delimited data) <ul style="list-style-type: none"> <li>■ 5a. Date</li> <li>■ 5b. Time</li> </ul>	8 characters (each)
6	Temperature	1 floating point
7	Calibration standard size	1 floating point
8	Number of purges	1 integer
9	Equilibration rates	1 floating point
10	Chamber Insert: <ul style="list-style-type: none"> <li>■ 0 = None</li> <li>■ 1 = 10 cm<sup>3</sup> (100 cm<sup>3</sup> unit) <p style="margin-left: 40px;">1 cm<sup>3</sup> (10 cm<sup>3</sup> unit)</p> <p style="margin-left: 40px;">0.1 cm<sup>3</sup> (1 cm<sup>3</sup> unit)</p> </li> <li>■ 2 = 35 cm<sup>3</sup> (100 cm<sup>3</sup> unit) <p style="margin-left: 40px;">3.5 cm<sup>3</sup> (10 cm<sup>3</sup> unit)</p> </li> </ul>	1 integer
11	Average cell volume	1 floating point
12	Cell volume standard deviation	1 floating point
13	Average expansion volume	1 floating point

## Calibration Report - Single Column (continued)

Record Number	Description	Form
14	Expansion volume standard deviation	1 floating point
15	Number of runs	1 integer
16	P1 (all P1 data)	1 floating point
17	P2 (all P2 data)	1 floating point
18	P1* (all P1* data)	1 floating point
19	P2* (all P2* data)	1 floating point
20	Include in average calculation <ul style="list-style-type: none"><li>■ 0 = Excluded</li><li>■ 1 = Included</li></ul>	1 integer

### Calibration Report - Spreadsheet

Record Number	Description	Form
1	Version Number	20 characters
2	Serial Number	1 integer
3	Report type = calibration	11 characters
4	Start (reported on one line as ASCII comma delimited data) <ul style="list-style-type: none"> <li>■ 4a. Date</li> <li>■ 4b. Time</li> </ul>	8 characters (each)
5	Stop (reported on one line as ASCII comma delimited data) <ul style="list-style-type: none"> <li>■ 5a. Date</li> <li>■ 5b. Time</li> </ul>	8 characters (each)
6	Temperature	1 floating point
7	Calibration standard size	1 floating point
8	Number of purges	1 integer
9	Equilibration rates	1 floating point
10	Chamber Insert: <ul style="list-style-type: none"> <li>■ 0 = None</li> <li>■ 1 = 10 cm<sup>3</sup> (100 cm<sup>3</sup> unit) <ul style="list-style-type: none"> <li>1 cm<sup>3</sup> (10 cm<sup>3</sup> unit)</li> <li>0.1 cm<sup>3</sup> (1 cm<sup>3</sup> unit)</li> </ul> </li> <li>■ 2 = 35 cm<sup>3</sup> (100 cm<sup>3</sup> unit) <ul style="list-style-type: none"> <li>3.5 cm<sup>3</sup> (10 cm<sup>3</sup> unit)</li> </ul> </li> </ul>	1 integer
11	Average cell volume	1 floating point
12	Cell volume standard deviation	1 floating point
13	Average expansion volume	1 floating point
14	Expansion volume standard deviation	1 floating point
15	Number of runs	1 integer

**Calibration Report - Spreadsheet (continued)**

<b>Record Number</b>	<b>Description</b>	<b>Form</b>
<b>16</b>	Carriage return / Line feed	
<b>17</b>	Carriage return / Line feed	
<b>18</b>	Carriage return / Line feed	
<b>19</b>	Run number and pressure (reported on one line as ASCII comma delimited data)	
<b>19a</b>	Run number	1 integer
<b>19b</b>	P1	1 floating point
<b>19c</b>	P2	1 floating point
<b>19d</b>	P1*	1 floating point
<b>19e</b>	P2*	1 floating point
<b>19f</b>	Include in average calculation <ul style="list-style-type: none"> <li>■ 0 = Excluded</li> <li>■ 1 = Included</li> </ul>	1 integer
<b>19g</b>	Cell volume	1 floating point
<b>19h</b>	Cell volume deviation	1 floating point
<b>19i</b>	Expansion volume	1 floating point
<b>19j</b>	Expansion volume deviation	1 floating point

**Blank Page**

---





## EU DECLARATION OF CONFORMITY

This declaration of conformity is issued under the sole responsibility of the manufacturer:

**Micromeritics Instrument Corporation**  
4356 Communications Drive  
Norcross, GA 30093, USA

Hereby declares that the product:

**AccuPyc II Automatic Gas Displacement Pycnometry System**  
**Model 1345 [Part Numbers: 134/5000X/20, where X = 0 through 5]**

is in conformity with the following EU harmonization legislation:

**2014/35/EU - LVD Directive**  
**2014/30/EU - EMC Directive**  
**2011/65/EU - RoHS Directive**

and that the equipment is in conformity with the following harmonized and other appropriate standards;

### **2014/35/EU (LVD)**

**EN 61010-1:2010 + A1:2019 - Safety requirements for electrical equipment for measurement, control, and laboratory use — Part 1: General requirements.**

### **2014/30/EU (EMC)**

**IEC 61326-1:2013 - Electrical equipment for measurement, control and laboratory use — EMC requirements — Part 1: General requirements**

**IEC 61000-3-2:2014 - Part 3-2: Limits — Limits for harmonic current emissions (equipment input current  $\leq$  16 A per phase)**

**IEC 61000-3-3:2013 - Part 3-3: Limits — Limitation of voltage changes, voltage fluctuations and flicker in public low-voltage supply systems, for equipment with rated current  $\leq$  16 A per phase and not subject to conditional connection**

### **2011/65/EU (RoHS)**

**EN 50581:2012 - Technical documentation for the assessment of electrical and electronic products with respect to the restriction of hazardous substances**

Name: John McCaffrey, Ph.D.

Title: Vice President, R & D

Signature: 

Date of issue: 12/28/2020

Location: Norcross, GA USA

**Blank Page**

---

## INDEX

---

### 0

0.1 cm<sup>3</sup> Insert  
 calibrate 15 - 5

### 1

1, 10, 3.5, 35, 650, and 1300 cm<sup>3</sup> Inserts  
 calibrate 15 - 6

### A

about this manual *iv*  
 AccuPyc, about 1 - 1  
 analysis  
   cancel 2 - 8  
   module  
     add to temperature controlled unit 14 - 2  
   parameter files 2 - 10  
   perform 6 - 1  
   perform using keypad 6 - 5  
   perform with software 6 - 3  
   QuickStart 6 - 7  
   review 6 - 9  
   sequence 6 - 8  
 analysis conditions  
   parameter file, pycnometry 5 - 2  
 analytical balance 11 - 3  
 analyzer  
   components 1 - 2  
   schematic 3 - 11  
   show status 3 - 13  
   status 3 - 10  
 asphalt density  
   application 1 - 5  
   measurement, TEC modules 13 - 4  
 axis cross-hair 7 - 13

### B

balance, analytical 11 - 3  
 brightness control 11 - 4

### C

calculations *iv*  
 calibrate  
   Insert  
     0.1cm<sup>3</sup> 15 - 5  
     1, 10, 3.5, 35, 650, and 1300 cm<sup>3</sup> Inserts 15 - 6  
   pressure scale 10 - 1  
   temperature offset 10 - 3  
   using the keypad 10 - 14  
   using the software 10 - 1  
   volume 10 - 16  
   volume scale 10 - 7  
   zero cell volume 10 - 4  
   zero pressure 10 - 5  
 calibrate function 10 - 14  
 calibration 10 - 1  
   chamber volume, zero 10 - 20  
   copy data 10 - 21  
   data, keypad 10 - 15  
   load data 10 - 21  
   load from file 10 - 13  
   pressure transducer, zero 10 - 20  
   report 10 - 2  
   reset pressure 10 - 6, 10 - 17  
   review 10 - 18  
   save to file 10 - 13  
   temperature 10 - 20  
   verify operation 10 - 11  
 cell leaks  
   check for 12 - 7  
   check using software 12 - 7  
   check using the keypad 12 - 7  
 chamber  
   cap O-Ring 12 - 5  
 circulating bath, attach 14 - 1  
 combined report  
   report example, pycnometry 7 - 19  
   report options 8 - 1

components  
  handling 11 - 5  
  instrument 1 - 2  
configuration  
  options 1 - 8  
contact us *iii*  
corporate profile *ii*

## D

data  
  review 2 - 13  
  view results 2 - 15  
data entry, keypad 2 - 1  
default methods 3 - 9  
density and volume table  
  report options 8 - 2  
density vs cycle number  
  report options 8 - 3  
density vs time  
  report options 8 - 5  
diagnostics  
  using software 9 - 1  
display 2 - 2

## E

EFUP *vii*  
environmentally friendly use period *vii*  
equilibration  
  report  
    report options 8 - 6  
equipment options and upgrades 1 - 7  
error messages *iv*  
expansion chamber  
  check for leaks 12 - 7  
  check for leaks using software 12 - 7  
  check for leaks using the keypad 12 - 7  
export files 3 - 14  
exported data example *B - 1*

## F

fields and buttons, common 3 - 2  
file status 3 - 7

files  
  export 3 - 14  
  list 3 - 14  
  open a sample file 3 - 15  
filter  
  dust, clean 12 - 9  
FoamPyc option 1 - 5

## G

gas  
  connect gas cylinder 12 - 13  
  disconnect gas cylinder 12 - 12  
  guidelines for connecting 12 - 11  
  replacement cylinder 12 - 12  
general safety *v*  
glove box 1 - 9  
graph  
  features and shortcuts 7 - 10  
  generate overlays 7 - 15  
  grid lines 7 - 14  
  report example, pycnometry 7 - 22  
  zoom feature 7 - 14

## H

handling system components 11 - 5  
hardware installation 11 - 1

## I

inserts  
  10, 3.5, and 35 cm<sup>3</sup> 15 - 4  
  operating parameters 15 - 6  
intended use *v*

## K

keypad  
  about 2 - 3  
  calibrate using 10 - 14

## L

### leaks

- check for 12 - 7
- check using software 12 - 7
- check using the keypad 12 - 7

### list files 3 - 14

### log

- show instrument 3 - 10

## M

### maintenance

- connect gas cylinder 12 - 13
- disconnect gas cylinder 12 - 12
- guidelines for connecting gases 12 - 11
- replacement cylinder 12 - 12

### manual mode 2 - 9

### manual, about this *iv*

### material parameters 4 - 6

### menu structure 3 - 1

### methods, default 3 - 9

### modules, connect 11 - 1

### multigas option 1 - 8, 16 - 1

### multivolume inserts 1 - 8, 15 - 1

## O

### option presentation 3 - 5

### options report

- report options 8 - 8

### overlays 7 - 17

- generate 7 - 15

- multiple graph 7 - 15

- report example, pycnometry 7 - 23

## P

### parameter files

- about 5 - 1

- analysis 2 - 10

- analysis conditions, pycnometry 5 - 2

### parts and accessories *iv*

### parts replacement 12 - 19

### power 12 - 4

### power analyzer on and off 12 - 18

### power failure, recover from 12 - 17

### pressure and volume table

- report options 8 - 8

### pressure calibration, reset 10 - 6

### pressure scale, calibrate 10 - 1

### print files 2 - 15

### pycnometer

- clean 12 - 10

- decontaminate 12 - 10

- High Pressure Core 1 - 7

- Large Volume Core 1 - 7

- reset 12 - 17

### Python module A - 1

- advanced reports A - 1

- get sample information item A - 17

- graphic report A - 3, A - 15

- MicModule Python calls A - 13

- overlay data A - 11

- reports A - 8

- scripts A - 6

- summary report A - 14

- tables A - 13

## Q

### QuickStart analysis 6 - 7

## R

### regulator pressure 12 - 15

### report examples

- combined report, pycnometry 7 - 19

- graph 7 - 22

- overlay, pycnometry 7 - 23

- sample log, pycnometry 7 - 25

- summary, pycnometry 7 - 20

- tabular, pycnometry 7 - 21

### report examples, pycnometry 7 - 19

### report options

- Density and Volume Table 8 - 2

- Density vs Cycle Number Trend Plot 8 - 3

- Density vs Time 8 - 5

- Equilibration Report 8 - 6

- Options Report 8 - 8
- Pressure and Volume Table 8 - 8
- Sample Log Report 8 - 9
- summary report, pycnometry 8 - 9
- Total Pore Volume vs Temp.,  
    pycnometry 8 - 10
- Volume vs Cycle, pycnometry 8 - 11
- report options, pycnometry 5 - 5
- reports
  - about 7 - 1
  - advanced, Python module A - 1
  - axis cross-hair 7 - 13
  - calibration 10 - 2
  - combined report 8 - 1
  - features and shortcuts 7 - 6
    - graphs 7 - 10
    - reports 7 - 6
    - tabular report 7 - 9
  - generate graph overlays 7 - 15
  - generate sample overlays 7 - 17
  - graph grid lines 7 - 14
  - header shortcuts 7 - 7
  - open and close 7 - 1
  - selected 8 - 1
  - SPC report options 7 - 2
  - start 7 - 1
  - toolbar 7 - 8
  - zoom feature 7 - 14
- reports, Python module A - 8
- review data 2 - 13
  - with web browser 2 - 13
- RS232 pin assignment 11 - 6

## S

- sample
  - load 6 - 1
  - log
    - report 8 - 9
    - report example, pycnometry 7 - 25
  - overlays 7 - 17
  - prepare 6 - 1
- sample cup properties, pycnometry 4 - 5
- sample file
  - about 4 - 1
  - create, pycnometry 4 - 1
  - open 3 - 15

- sample volume equation derivation C - 1
- schematic
  - instrument 3 - 11
  - shortcuts 3 - 12
- sequence analysis 6 - 8
- service test mode 12 - 19
- shortcuts
  - report header 7 - 7
  - schematic 3 - 12
- shortcuts, application 3 - 8
- show instrument log 3 - 10
- show instrument schematic 3 - 11
- software
  - about 3 - 1
  - for 21CFR11 3 - 19
  - reinstall or modify 3 - 17
  - updates 3 - 16
- software uninstall 3 - 18, 3 - 23
- SPC report 7 - 2
- specifications 1 - 11
  - TEC 1 - 15
- status
  - analyzer 3 - 10, 3 - 13
- summary
  - report example, pycnometry 7 - 20
- summary report, pycnometry 8 - 9
- system commands 2 - 6

## T

- tabular reports
  - features and shortcuts 7 - 9
  - report example, pycnometry 7 - 21
- TEC module 1 - 4, 13 - 1
  - Asphalt Density Measurement 13 - 4
  - operate 13 - 2
  - set temperature 13 - 1
- temperature controlled module 1 - 9, 14 - 1
  - Add an Analysis Module 14 - 2
- temperature offset, calibrate 10 - 3
- toolbar, report 7 - 8
- total pore volume
  - vs Temperature
    - report options 8 - 10
- transmit 2 - 10
- transmitted data
  - data units D - 1

troubleshooting  
and maintenance 12 - 1  
service test mode 12 - 19

## U

unit selection 3 - 18

## V

volume scale  
calibrate 10 - 7  
volume vs cycle  
report options, pycnometry 8 - 11  
volume, calibrate 10 - 16

## W

warranty *i*

## Z

zero cell volume, calibrate 10 - 4  
zero pressure, calibrate 10 - 5